

MODEL	WORK SPACE W x D x H	KW	BTU/HR	CFM	MOTOR H. P.	INSULATION THICKNESS	"A"	"B"	"C"	"D"	"E"	"F"	"G"	"H"	"J"
HC-550	50" x 50" x 50"	30	150,000	2,450	1 1/2	6"	74"	9"	83"	62"	4"	66"	88 1/2"	46"	9"
HC-700	50" x 50" x 50"	40	200,000	2,450	1 1/2	7"	76"	9"	85"	64"	4"	68"	90 1/2"	47"	10"
HC-850	50" x 50" x 50"	60	300,000	3,300	2	8"	78"	9"	87"	66"	4"	70"	92 1/2"	48"	11"

OPTIONAL POWERED FORCED EXHAUSTER DIMENSIONS

MODEL	80 CFM				130 CFM				325 CFM				650 CFM			
	"K"	"L"	"M"	"N"	"K"	"L"	"M"	"N"	"K"	"L"	"M"	"N"	"K"	"L"	"M"	"N"
HC-550	15 3/16"	43 9/16"	17 1/8"	4"	16"	41 7/8"	20 1/2"	4"	16 1/8"	39 1/2"	23"	6"	17 3/4"	39 1/2"	23"	6"
HC-700					17"	42 7/8"	20 1/2"	4"	17 1/8"	40 1/2"	23"	6"	18 3/4"	40 1/2"	23"	6"
HC-850					18"	43 7/8"	20 1/2"	4"	18 1/8"	41 1/2"	23"	6"	19 3/4"	41 1/2"	23"	6"

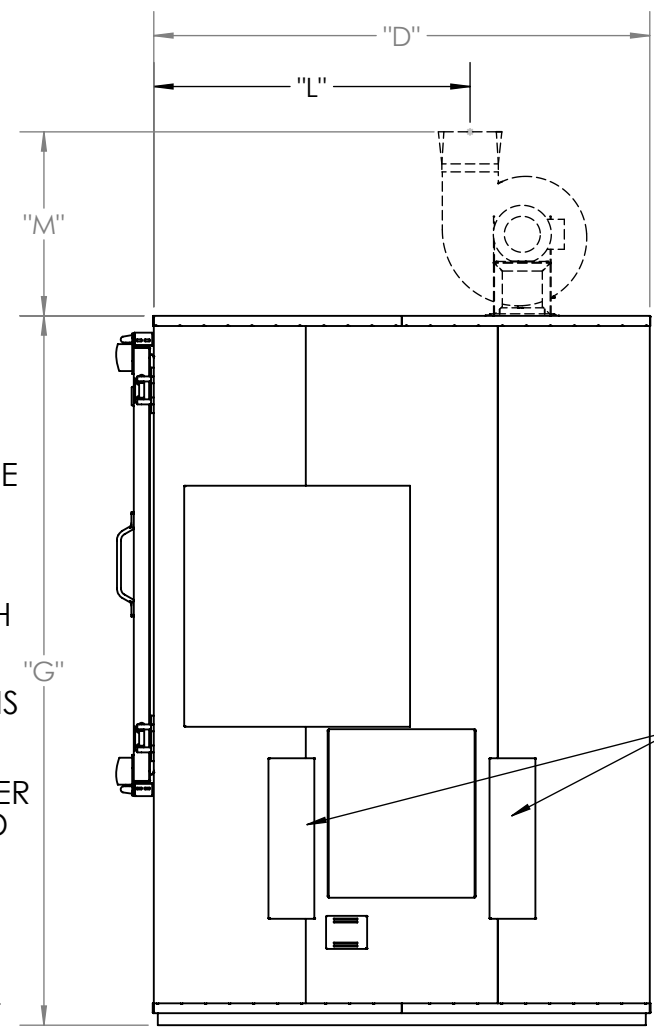
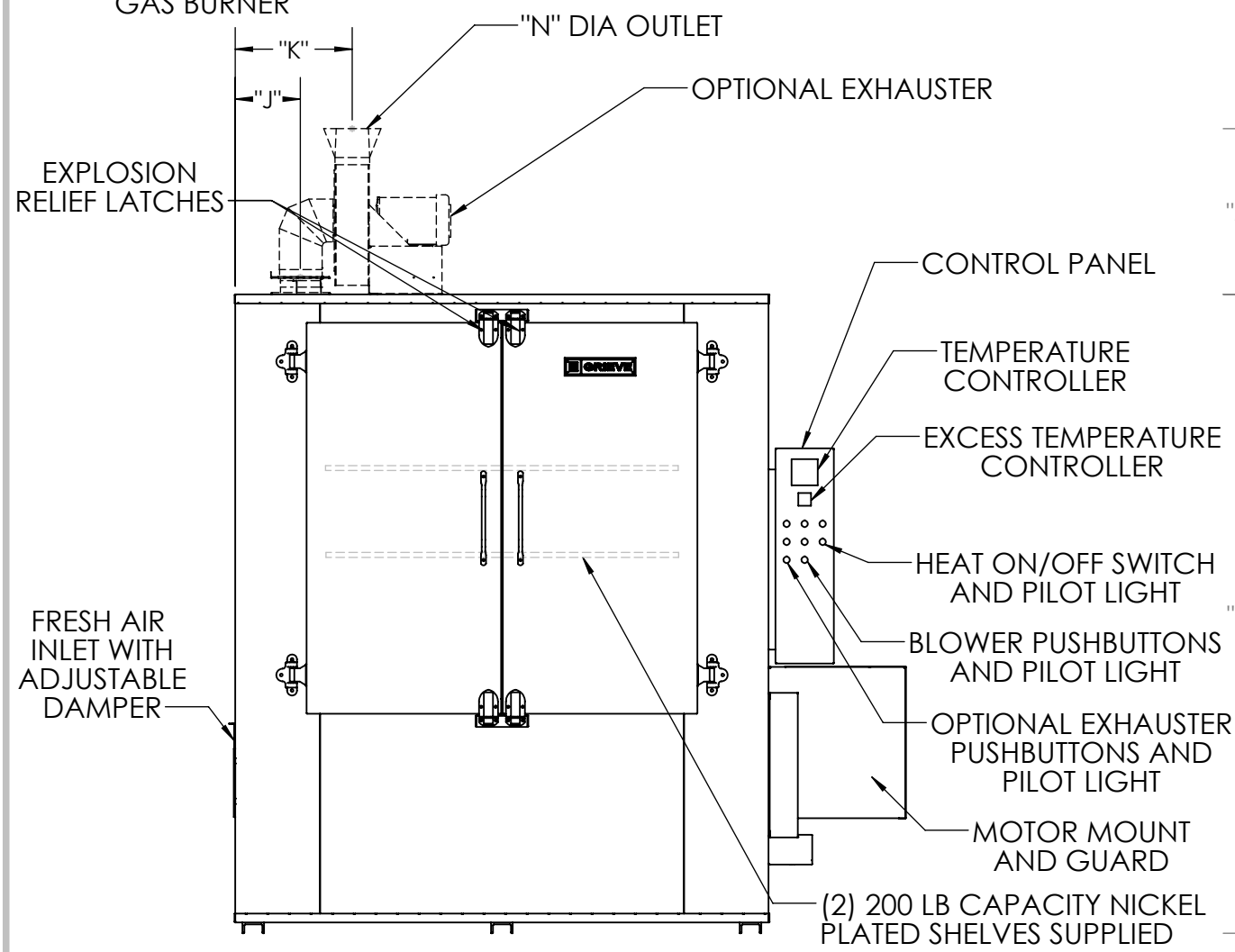

- NOTE
- 1 STANDARD ELECTRICAL SERVICE: 208/3/60, 230/3/60, 460/3/60
 - 2 STANDARD GAS SERVICE: 1,000 BTU NATURAL GAS AT 6" - 8" W.C. PRESSURE. OTHER GAS SERVICE ALSO AVAILABLE
 - 3 AIR FLOW: HORIZONTAL
 - 4 INTERIOR: 304 STAINLESS STEEL, WITH CARBON STEEL BLOWER WHEEL
 - 5 EXTERIOR: ALUMINIZED STEEL, PAINTED TRILITE GREEN MACHINERY ENAMEL
 - 6 GAS OVENS INCLUDE 325 CFM EXHAUSTER

REV.	DESCRIPTION	BY	DATE
	DESCRIPTION		
	CUSTOMER		
	MODEL		
	HC-550, HC-700, HC-850 CABINET OVENS		
	SHOP ORDER		
	DRAWN BY JC		DWG. NO. HC550
	DATE	PRINT DATE 5/14/2013	HC850

This drawing is the property of THE GRIEVE CORPORATION, and may not be used or reproduced without the express permission of THE GRIEVE CORPORATION