

EXHAUSTER PLATFORM INCLUDED WITH EXHAUSTER ONLY

4" DIA GRAVITY EXHAUST WITH ADJUSTABLE DAMPER

OVEN DIMENSIONS

MODEL	WORK SPACE W x D x H	KW	VOLUME CU. FT.	CFM	MOTOR H. P.	INSULATION THICKNESS	"A"	"B"	"C"	"D"	"E"	"F"	"G"	"H"	"J"
AG-1050	36" x 48" x 36"	24	36	1200	1	10"	63"	9"	72"	78"	5"	83"	56"	66"	31 1/2"
AG-1250	36" x 48" x 36"	30	36	1400	1 1/2	12"	67"	9"	76"	82"	5"	87"	60"	68"	33 1/2"

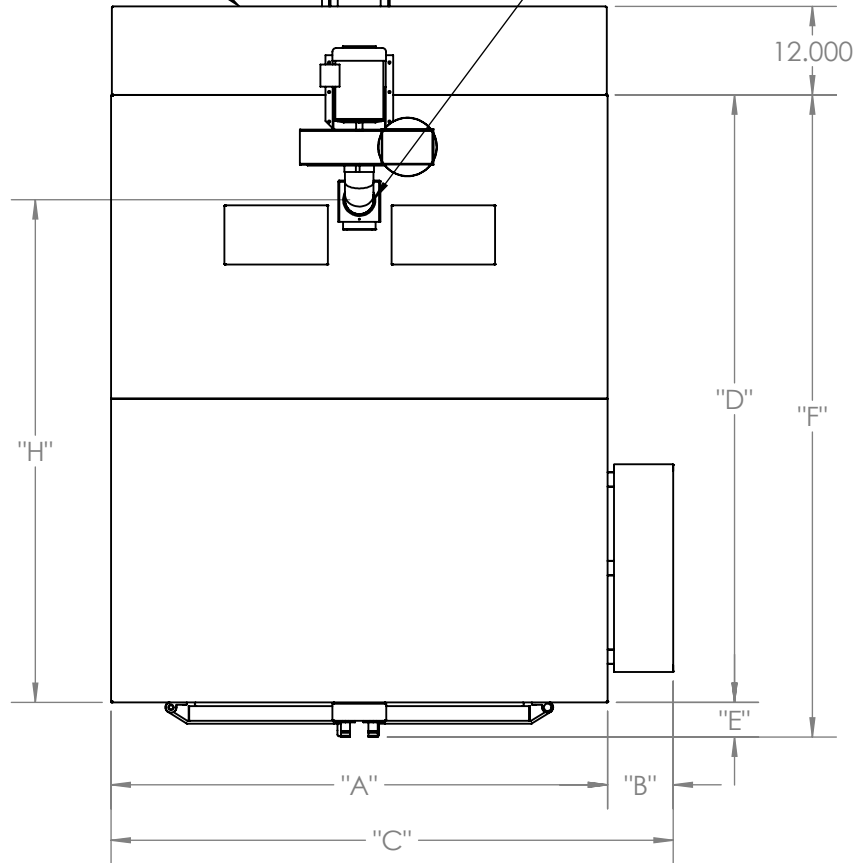

OPTIONAL POWERED FORCED EXHAUSTER DIMENSIONS

MODEL	130 CFM				325 CFM			
	"K"	"L"	"M"	"N"	"K"	"L"	"M"	"N"
AG-1050	35 5/8"	73"	20 1/2"	4"	38"	73 1/8"	23"	6"
AG-1250	37 5/8"	75"	20 1/2"	4"	40"	75 1/8"	23"	6"

NOTE

- 1 STANDARD ELECTRICAL SERVICE: 208/3/60, 230/3/60, 460/3/60
- 2 AIR FLOW: HORIZONTAL, FRONT TO BACK
- 3 INTERIOR: 304 STAINLESS STEEL, WITH STAINLESS STEEL BLOWER WHEEL
- 4 EXTERIOR: ALUMINIZED STEEL, PAINTED TRILITE GREEN MACHINERY ENAMEL

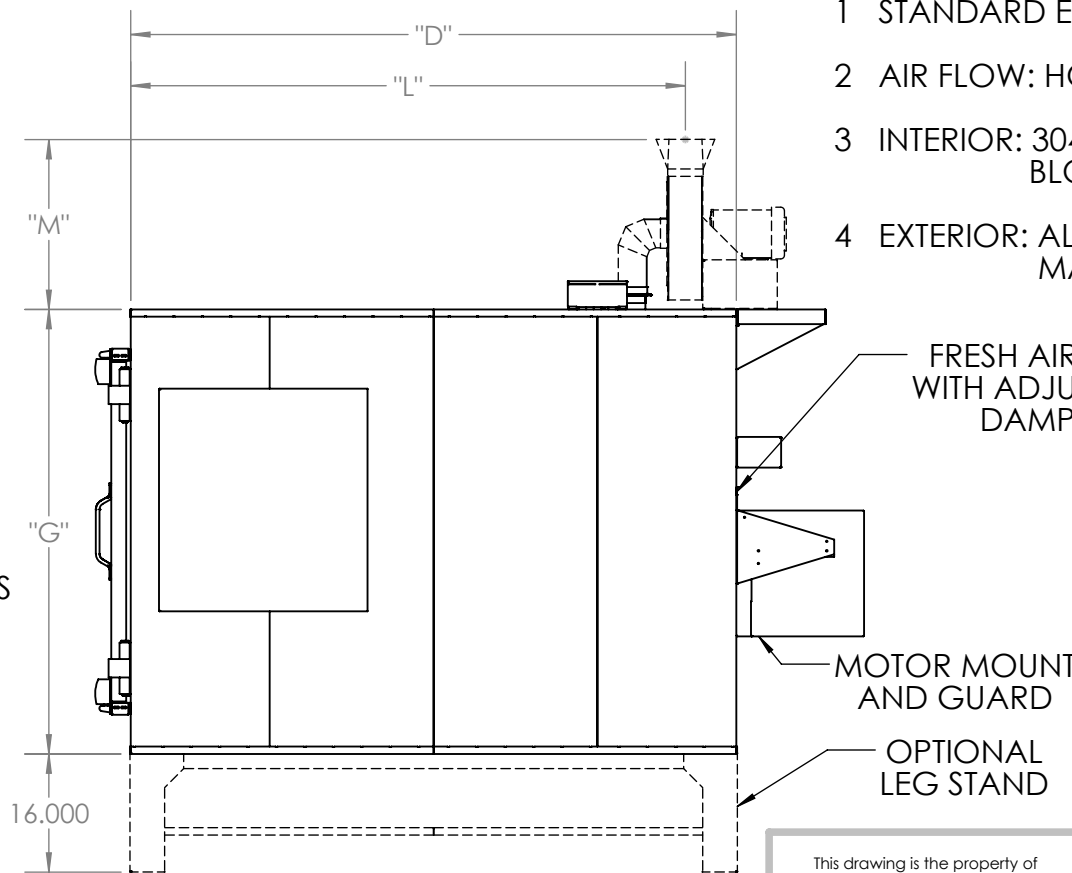
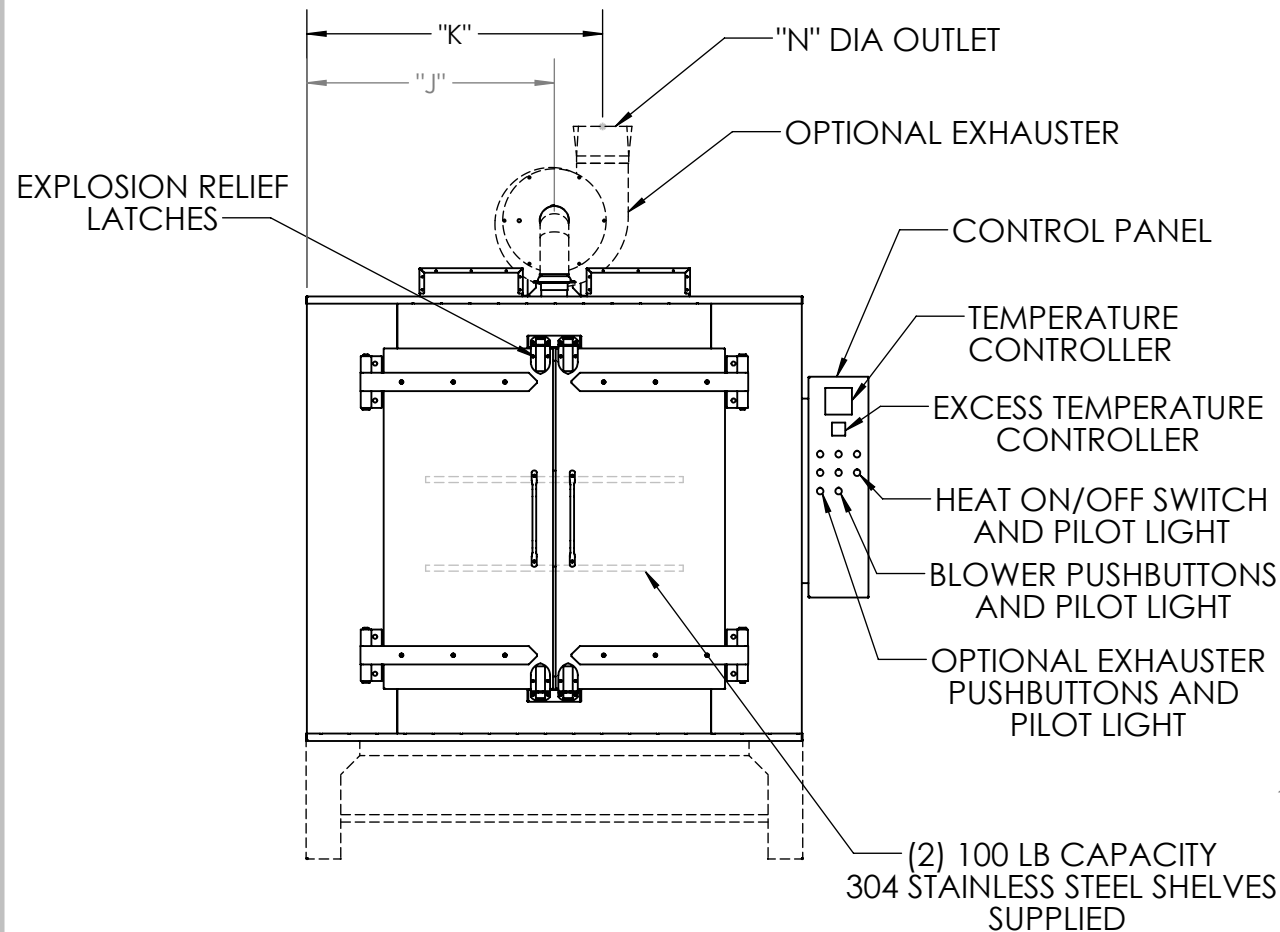

This drawing is the property of THE GRIEVE CORPORATION, and may not be used or reproduced without the express permission of THE GRIEVE CORPORATION

REV.	DESCRIPTION	BY	DATE
DESCRIPTION			
CUSTOMER			
MODEL AG-1050, AG-1250 HIGH TEMPERATURE HORIZONTAL UNIVERSAL OVENS			
SHOP ORDER			
DRAWN BY JC		DWG. NO. AG-1050 AG-1250	
DATE		PRINT DATE 9/19/2011	