

## V4046C, V8046C Magnetic Valves

### PRODUCT DATA



### APPLICATION

The V4046C and V8046C Magnetic Valves provide on-off control of gas flow in supply line.

### FEATURES

- Normally closed valves which open immediately when energized.
- V4046C is for line voltage applications; V8046C is for 24 Vac applications.
- Provides on-off control of manufactured, Liquefied Petroleum (LP), and natural gases with high sulfur content.
- Used with pilot burners in industrial applications.
- All models close in one second (maximum) on power failure.
- Heavily loaded spring plunger maintains valve seating when the coil is de-energized, permitting the valve to be mounted in any position.
- Valve may be pipe-mounted or mounted on bracket support furnished by installer.
- Powerhead assembly can be rotated 360 angular degrees.
- Solenoid coil is field-replaceable without removing the valve body from the piping connection.

### Contents

Application .....	1
Features .....	1
Specifications .....	2
Ordering Information .....	2
Installation .....	4
Wiring .....	5
Checkout and Service .....	5



# SPECIFICATIONS

**Models:** See Table 1.

**Table 1. Model Specifications.**

Model	Pressure Rating <sup>a</sup>		Gas Flow		Gas Heat Capacity <sup>a</sup>	Operation Energized	Voltages (60 Hz)
	psi	kPa	cfh <sup>b</sup>	m/hr	btuh <sup>c</sup>		
V4046C	10	69	20	0.57	20,000	Opens Immediately	120
			55	1.56	55,000		208
			67	1.90	67,700		
V8046C			20	0.57	20,000		24
			55	1.56	55,000		
			67	1.90	67,700		

<sup>a</sup> 1/2 psi in AGA rating.

<sup>b</sup> See body sizes, Fig. 2. 55 cfh (1.56 cmh) is for large body valve with 1/4-18 NPT threads; 67 cfh (1.90 cmh) is for large body valve with 3/8-18 NPT threads.

<sup>c</sup> Natural gas, 1000 btu/cu ft measured at one inch pressure drop, 0.64 specific gravity. See Gas Capacity Conversion Factors.

**Table 2. Coil VA Ratings.**

Model	24 Vac, 60 Hz	120 Vac, 60 Hz	208 Vac, 60 Hz
V4046C	—	13.8	13.7
V8046C	14.1	—	—

**Types of Gas:** Suitable for all domestic gases including high sulfur content LP gas.

**Valve Material:** Aluminum.

**Valve Pattern:** Straight-through.

**Pipe Size:** See Fig. 1.

**Valve Action on Power Failure:** All models close in one second maximum.

**Mounting:**

Can be mounted in any position. Mounts directly in pipe line or on a support bracket. See Fig. 2 for tapped holes provided in bottom of valve body. Conduit outlet on powerhead can be rotated through 360 degrees with respect to valve body.

**Wiring Connection:** Two 36-in. (915 mm) leadwires; 1/2 in. conduit bushing.

**Ambient Temperature Range:** -40°F to +125°F (-40°C to +54°C).

**Approvals:**

Underwriters Laboratories, Inc. Listed: File NO. MH1639, V3, S3; Guide No. YIOZ; V4046C, V8046C for gas.  
 Factory Mutual Listed: V4046C, V8046C for gas.  
 CSA 158158-250000605.8, Guide Numbers C3371-03, 83. (60 Hz models only).

**Replacement Parts:** Coil assemblies include coil, leadwire, insulator and bobbin. See Table 3.

**Table 3. Coil Assemblies for V4046C, V8046C Valves.**

Part Number	Used On
116671A	V4046C; 120 Vac, 60 Hz
116782A	V4046C; 208 Vac, 60 Hz
11668A	V8046C; 24 Vac, 60 Hz

# ORDERING INFORMATION

When purchasing replacement and modernization products from your TRADELINE® wholesaler or distributor, refer to the TRADELINE® Catalog or price sheets for complete ordering number.

If you have additional questions, need further information, or would like to comment on our products or services, please write or phone:

1. Your local Home and Building Control Sales Office (check white pages of your phone directory).
2. Home and Building Control Customer Relations  
 Honeywell, 1885 Douglas Drive North  
 Minneapolis, Minnesota 55422-4386

In Canada—Honeywell Limited/Honeywell Limitée, 35 Dynamic Drive, Scarborough, Ontario M1V 4Z9.

International Sales and Service Offices in all principal cities of the world. Manufacturing in Australia, Canada, Finland, France, Germany, Japan, Mexico, Netherlands, Spain, Taiwan, United Kingdom, U.S.A.

## Gas Valve Sizing

1. Check the burner nameplate for:
  - a. the type of gas used, and
  - b. the gas flow capacity. The capacity will be listed in British thermal units per hour (Btuh) or in cubic feet per hour (cfh).
2. Contact the local gas utility for information regarding:
  - a. the specific gravity (sp gr) and
  - b. the Btu per cubic foot (Btucf) for the type of gas used.
3. Find the capacity in cfh. If the capacity is listed in Btu, convert to cfh using the following formula:  

$$\text{Capacity in cfh} = \frac{\text{Btuh (burner nameplate)}}{\text{Btu/cu ft (gas utility)}}$$
4. For gases with specific gravity other than 0.64, multiply the burner cfh using the proper conversion factor in Table 4.

**Table 4. Gas Conversion Factors.**

Type of Gas	sp gr (average)	Multiply cfh by
Manufactured	0.60	0.968
Mixed	0.70	1.046
LP-Propane	1.53	1.546
LP-Butane	1.98	1.759

5. Use the corrected burner capacity in cfh when determining the gas valve size in Fig. 1.
6. Determine the maximum pressure drop to be taken across the valve. If pressure drop is not in pounds per square inch (psi), multiply the value in known pressure units by the conversion factor.
7. Plot the capacity (cfh) vs. pressure drop (psi) in Fig. 1 to find the proper valve size.

NOTE: Use the corrected cfh for gas other than 0.64 sp gr.

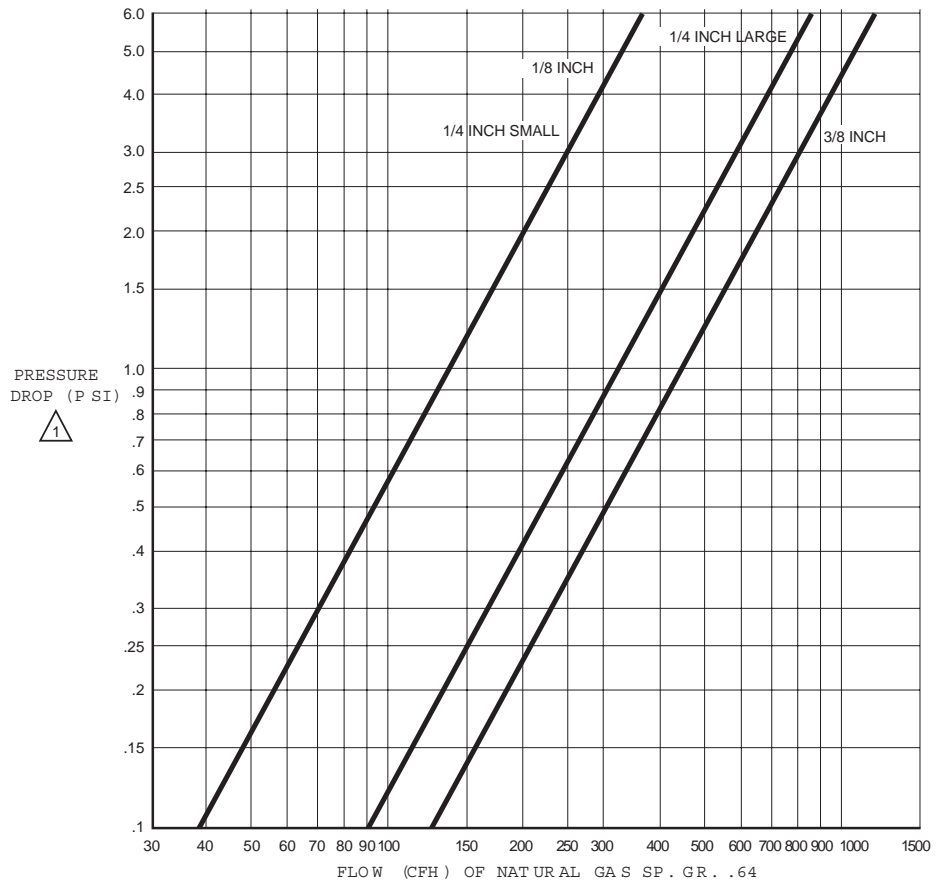

△ TO CONVERT PRESSURE DROP IN INCHES WC TO PSI UNITS, MULTIPLY UNITS IN INCHES WC By .0361.  
 TO CONVERT PRESSURE DROP FROM PSI TO INCHES WC, MULTIPLY UNITS IN PSI BY 27.7.

M20743B

**Fig. 1. Pressure drop (psi) vs. flow capacity (cfh) on V4046C, V8046C gas valves only.**

Dimensions. See Fig. 2.

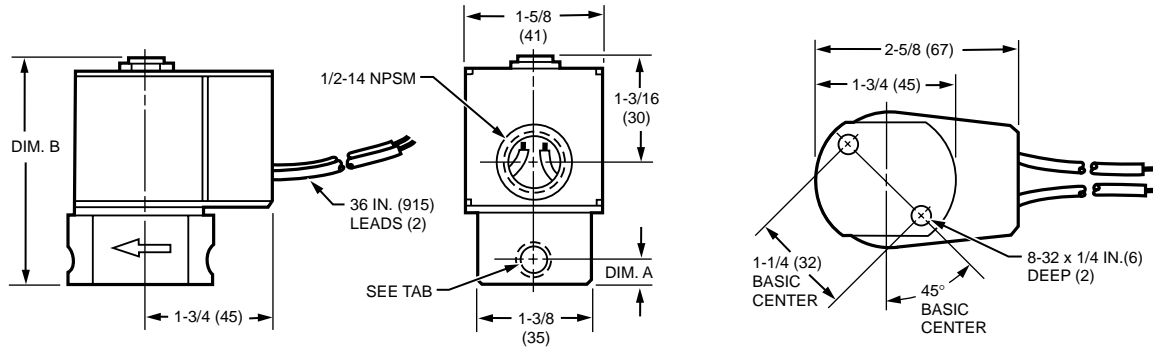

MODEL	BODY SIZE	THREAD SIZE	DIM. A		DIM. B	
			IN	MM	IN	MM
V4046C, V8046C	SMALL	1/8-27 NPT	5/16	8	2-3/4	70
	SMALL	1/4-18 NPT	3/8	10	3	76
	LARGE	1/4-18 NPT	1/2	13	3-1/4	83
	LARGE	3/8-18 NPT	1/2	13	3-1/4	83

M16595

Fig. 2. V4046C, V8046C approximate dimensions in in. (mm).

## INSTALLATION

### When Installing This Product...

1. Read these instructions carefully. Failure to follow them could damage the product or cause a hazardous condition.
2. Check the ratings given in the instructions and on the product to make sure the product is suitable for your application.
3. The installer must be a trained, experienced flame safeguard technician.
4. After installation is complete, check out product operation as provided in these instructions.

## ⚠ WARNING

**Explosion and Electrical Shock Hazard.**  
Can cause serious injury, death or property damage.

1. Turn off gas supply before beginning installation.
2. Disconnect electrical power before beginning installation or servicing procedure. More than one disconnect can be involved.
3. To avoid damage or distortion of the valve when installing rigid or flexible conduit, the conduit fittings should not be subjected to more than 5 ft-lbs torque when screwing the fitting into the valve coil case (powerhead). An approximation of 5 ft-lbs torque is hand-tightened plus 1/8 turn. When securing the rigid or flexible conduit in the conduit fitting using the setscrew, use only enough force to secure the conduit to avoid damage/distortion of the valve.
4. Always loosen the coil nut before attempting to rotate the powerhead.
5. Do not tighten the valve on the gas pipe using the coil housing (powerhead) as a handle.

## Gas and Air Installations

Mount the gas valves in the pilot gas supply line upstream from the burner. Ambient temperatures at the valve location must be within -40°F to +125°F (-40°C to +54°C).

## Mounting

The V4046C and V8046C Valves will operate in any mounting position required by the installation, as long as gas flow is in the direction indicated by the arrow.

Use iron pipe for at least one of the valve connections to insure adequate support and to confirm with recommendations of Underwriters Laboratories, Inc.

If the installation does not support the valve adequately, a mounting bracket should be devised and installed.

## Preparing Piping and Installing Valve

1. Use new, properly reamed pipe, free from chips.
2. Do not thread pipe too far. Valve distortion or valve malfunction may result from excess pipe in valve.
3. Apply a moderate amount of good quality pipe dope to the pipe only (see Fig. 3). If pipe dope lodges on the valve seat, it will prevent proper closure. If using LP gas, use pipe dope resistant to action of LP gas.
4. Install the valve with gas flow in the direction indicated by the arrow on the valve body. Gas must be in the same direction as indicated by the arrow.
5. Move the powerhead to the desired position and then tighten the hexagonal nut located on the top of the valve.

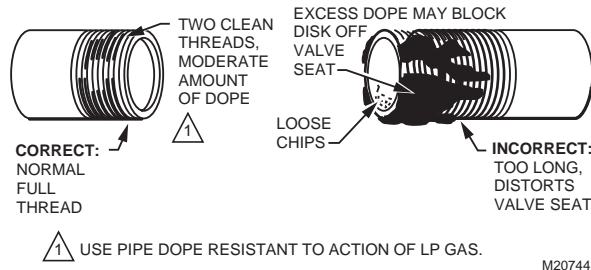

Fig. 3. Preparing the pipe threads.

## Gas and Air Applications

Test for leaks by painting pipe joints with a soapy solution. Excessive bubbles indicate a leak.

## WIRING

### **⚠ WARNING**

**Electrical Shock Hazard.**  
**Can cause serious injury or death.**  
 Disconnect power supply before wiring to prevent electrical shock or equipment damage. More than one disconnect can be involved.

All wiring must conform to local codes and ordinances.

Leadwires on these devices are long enough to reach the junction box on most burner installation. The powerhead on all models rotates 360 degrees, permitting the electrical service to be brought to it from any convenient direction.

See Fig. 4 and 5 for typical wiring hookups for V4046C and V8046C, respectively.

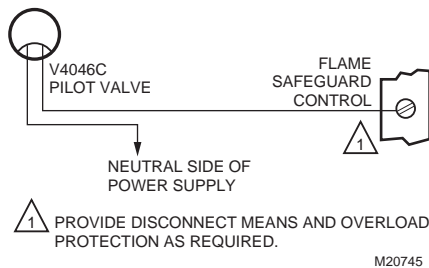

Fig. 4. Typical hookup of V4046C. See Flame Safeguard wiring diagram to determine correct terminal for pilot valve connection.

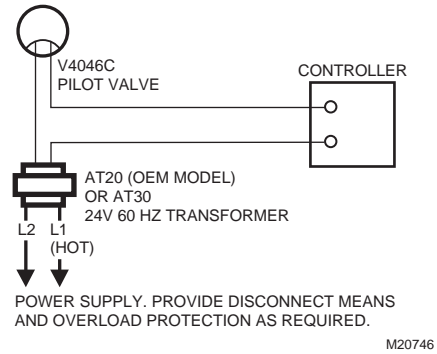

Fig. 5. Typical hookup of V8046C.

## CHECKOUT AND SERVICE

### Checkout

Put the system in operation and observe through at least one cycle to be sure valve functions as described.

**NOTE:** Valve clicks audibly when it opens and when it closes. Listen for clicks to make sure valve is opening and closing properly.

### Service

#### **IMPORTANT**

*Do not assume that the valve needs replacement until all other sources of trouble have been eliminated.*

#### **If the valve will not open when the thermostat and limit control are calling for heat:**

1. Make sure that the pilot is burning properly, the Pilotstat® Control (if used) is holding in, and the limit control contacts are closed.
2. Make sure that normal gas pressure is available at the valve.
3. Make sure that the bleed line is unobstructed.
4. Check the power supply at the valve. If no voltage is indicated, check the power source (transformer or line source) and circuit controls. If proper voltage is present at the valve, but the valve does not pull in, replace the valve coil.

#### **If the valve will not close with one or more of the control contacts open:**

1. Make sure that the gas flow is in the direction of the arrow on the valve body.
2. Check for a short in the wiring circuit.

## Maintenance

### **⚠ WARNING**

**Electrical Shock Hazard.**

**Can cause serious injury or death.**

Disconnect the power supply before replacing the solenoid coil. More than one disconnect can be involved.

The V4046C and V8046C Magnetic Valves are built to give long and reliable service without attention. If necessary, the solenoid coil is replaced as follows (see Fig. 6):

1. Disconnect the power supply before replacing the solenoid coil.
2. Remove the nut on top of the valve by turning it counterclockwise .
3. Lift the powerhead assembly off the spindle.
4. Disconnect and remove the solenoid coil.
5. Connect the replacement coil and reassemble.

NOTE: The valve need not be removed from the pipe installation to change the solenoid coil.

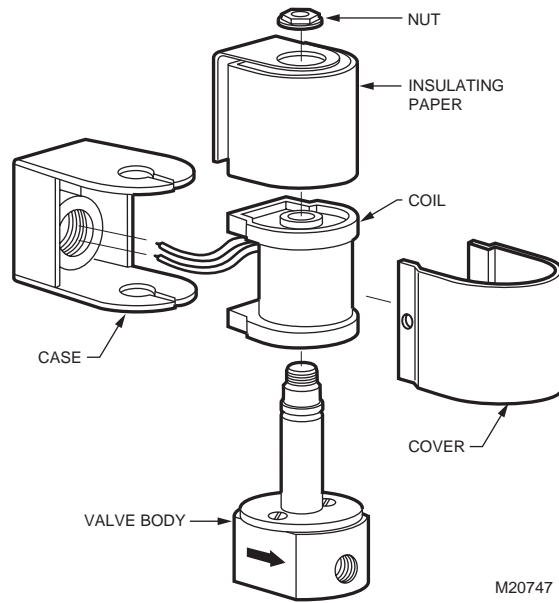

**Fig. 6. Removing the solenoid coil.**



**Honeywell**

---

**Automation and Control Solutions**

Honeywell  
1985 Douglas Drive North  
Golden Valley, MN 55422

Honeywell Limited-Honeywell Limitée  
35 Dynamic Drive  
Scarborough, Ontario  
M1V 4Z9

