

GENERAL INSTALLATION, OPERATION AND MAINTENANCE INSTRUCTIONS FOR FURNACES

TABLE OF CONTENTS

1	SHIPPING DAMAGE & HANDLING
2	PROPER FURNACE APPLICATION
2-1	General
2-2	Flammable Solvents
2-3	Combustible Material
2-4	Personnel Hazards
2-5	Maintenance and Inspection
3	INSTALLATION
3-1	Location
3-2	Building Considerations
3-3	Clearances
3-4	Ventilation
3-5	Exhaust Ductwork
3-6	Fuel Gas Supply
3-7	Electrical
4	PRIOR TO PLACING FURNACE IN SERVICE
5	PROCESSING
6	SAFETY EQUIPMENT
7	MAINTENANCE
8	TROUBLE SHOOTING
9	APPENDIX A - SAFETY EQUIPMENT, DESCRIPTION & OPERATION
10	APPENDIX B - REFERENCES
11	APPENDIX C - MINIMUM PERIODIC MAINTENANCE REPORT
12	APPENDIX D - SAFETY SHUT OFF VALVE LEAK TEST PROCEDURE
13	APPENDIX E - WARRANTY AND LIMITATIONS OF REMEDIES

Following these **GENERAL INSTRUCTIONS** in your manual are the following:

- OPERATING INSTRUCTIONS SPECIFIC FOR YOUR EQUIPMENT
- MECHANICAL PARTS LIST
- ELECTRICAL WIRING AND COMPONENT PARTS LIST
- LITERATURE AND INSTRUCTIONS ON COMPONENTS

These **GENERAL INSTRUCTIONS** have been written for many different types of furnaces, therefore, some equipment or components referred to may not be present on your particular piece of equipment.

After reading these **GENERAL INSTRUCTIONS**, also read the specific **OPERATING INSTRUCTIONS** written for your equipment. An additional copy of the **OPERATING INSTRUCTIONS** is provided in a plastic cover. Post these instructions at the furnace for the operator to reference.

1 SHIPPING DAMAGE AND HANDLING

DO NOT RETURN DAMAGED MERCHANDISE TO US. FILE YOUR CLAIM AS OUTLINED BELOW

This merchandise has been thoroughly inspected and carefully packed before leaving our plant. Responsibility for its safe delivery was assumed by the carrier at the time of shipment. Claims for loss or damage to the contents must be made with the carrier, as follows:

1-1 VISIBLE LOSS OR DAMAGE

Any external evidence of loss or damage must be noted, at the time of delivery, on the freight bill or express receipt and signed by the carrier's agent. Failure to adequately describe such external evidence of loss or damage may result in the carrier refusing to honor a damage claim. Make a written request for inspection by the carrier's agent within fifteen days of the delivery date. Review the inspection report and do not sign it unless it adequately describes the damage.

A claim must be filed with the carrier since such damage is the carrier's responsibility.

1-2 CONCEALED LOSS OR DAMAGE

Concealed loss or damage means loss or damage which does not become apparent until the merchandise has been unpacked. The contents may be damaged in transit due to rough handling even though the carton may not show external damage. When the damage is discovered upon unpacking, contact the carrier and make a written request for inspection by the carrier's agent within fifteen days of the delivery date. Review the inspection report and do not sign it unless it adequately describes the damage.

A claim must be filed with the carrier since such damage is the carrier's responsibility. By following these instructions carefully, we guarantee our full support of your claims to protect you against loss from concealed damage.

1-3 RETURNING DAMAGED EQUIPMENT

Damaged equipment will not be accepted at our factory unless we have been advised and instructions provided on how it should be returned. A copy of the freight claim must be provided prior to returning the equipment.

1-4 HANDLING

After inspection, store and handle all equipment and components in their original crates until ready for installation. Handle with care. The equipment may be heavy but some components are of a delicate nature. If the equipment is to be stored, keep it in the original crates and store in a location free from excessive dust, heat and moisture until ready for installation.

2 PROPER FURNACE APPLICATION

2-1 GENERAL

2-1.1 While furnaces are extremely versatile, they are usually purchased with a specific application in mind. If your process has changed significantly or if you should have reason to doubt that a specific application is a proper use of the equipment, consult the factory before proceeding.

2-1.2 Explanatory Material (Annex A1.1) of the National Fire Protection Association Publication 86 "Standard for Ovens and Furnaces" states; in part:

"Explosions and fires in fuel-fired and electric heat utilization equipment constitute a loss potential in life, property and production."

Most failures can be traced back to human error. The most significant failures include inadequate training of operators, lack of proper maintenance, and improper application of equipment."

2-1.3 To protect the furnace, furnace contents, property and personnel, a responsible person should be in attendance during operation. **Do not operate furnace unattended.** Special attention must be paid to:

- Setting correct temperature.

- Placing flammable solvents in a furnace not designed for that purpose.

- Placing combustibles in a furnace that does not have adequate fire protection.

- Allowing the product to remain in the furnace too long, thereby encouraging combustion.

- Using a furnace for a process other than that for which it was designed.

2-1.4 Furnace operator should shut down the furnace immediately and notify their supervisor if there are changes in furnace performance, a safety interlock trips or, in the case of fuel fired equipment, the smell of natural gas or propane is present. The furnace should not be put back into production until the causes are found and corrected.

2.2 FLAMMABLE SOLVENTS

2-2.1 Processing solvents in a non-solvent furnace, exceeding the design temperature, or exceeding the maximum amount of solvent allowed in a furnace, could result in **fire or explosion** and bodily injury or property loss.

If flammable solvents or vapors will be present in a furnace, the Occupational Safety & Health Administration (OSHA) requires that it have a separately powered forced exhaustor of adequate size and other related safety devices not supplied as standard equipment. Furnaces designed for this purpose have a caution plate and Furnace Design Data Form showing the maximum gallons of solvent, or pounds of powder coating, and the maximum operating temperature for which that specific furnace has been designed. If in doubt, consult factory for details.

2-2.2 It shall be the user's responsibility to ensure that the amount of flammable solvent placed in the furnace and the operating temperature does not exceed the design capacity -- see Safety Design Form and furnace caution nameplate.

- 2-2.3** In areas outside of the furnace where flammable solvents are given off by material prior to entering the furnace, provisions should be made to exhaust these vapors to atmosphere to prevent them from being pulled into the furnace or collecting and creating a flammable mixture.

2-3 COMBUSTIBLE MATERIAL

- 2-3.1** Introduction of combustible materials (such as paper, cardboard or wood) into the furnace should be avoided because it might cause a fire. Do not use combustible racks, trays, holders, spacers, etc. Periodically, clean all combustible material from non-combustible racks, trays, holders, spacers, etc. If combustible products must be processed in a furnace, extreme care must be taken to ensure that the operating temperature does not exceed the ignition temperature of the product.

- 2-3.2** Furnaces containing or processing sufficient combustible materials (including consideration for combustible drippings or deposits) to sustain a fire shall be equipped with an automatic fire protection system including areas in exhaust ducts that could accumulate combustible material. Fire protection systems should be installed in accordance with the applicable National Fire Protection Guidelines:

- Sprinkler Systems in accordance with NFPA 13
- Water Spray Systems in accordance with NFPA 15
- Carbon Dioxide Extinguishing Systems in accordance with NFPA 12
- Foam Extinguishing Systems in accordance with NFPA 11
- Dry Chemical Extinguishing Systems in accordance with NFPA 17
- Water Mist Systems in accordance with NFPA 750

The extent of protection required will depend upon the construction and arrangement of the furnace as well as the materials handled. Fixed protection, such as automatic sprinklers or other types of fire extinguishing systems, should be designed and installed by a qualified contractor.

- 2-3.2.1** Activation of fire protection system shall comply with NFPA 86 11.5 providing
- safety shut down of furnace
 - discontinue introduction of flammable or combustible material
 - position dampers to maintain minimum air flow through furnace to prevent combustible concentration from exceeding 25% of lower flammable limit (LFL)
 - keep fans in operation to maintain required safety ventilation to prevent combustible concentration from exceeding 25% of lower explosive limit (LEL)
 - shut down recirculation and exhaust fans and close dampers where type of fire protection requires that ventilation be discontinued

- 2-3.3** Drip pans shall be provided to collect any combustible materials that may accumulate beneath the product. A maintenance program must be developed to remove any such accumulation before a substantial build-up occurs that could spontaneously ignite and cause a fire. If you cannot acquire drip pans locally, contact us for a quotation.

2-4 PERSONNEL HAZARDS

- 2-4.1** You must analyze your use of this equipment and determine if it creates a confined space hazard, as defined by OSHA, in your work place. You are responsible for posting appropriate warnings and complying with applicable OSHA STANDARDS pertaining to confined space hazards. (Reference ANSI Z117-1 Safety Requirements for Confined Spaces, see Appendix B)

- 2-4.2** If inert atmospheres are to be used, keep in mind that inert gases displace air and create oxygen-deficient atmospheres. For this reason, they can cause suffocation. Moreover, some inert gases, such as argon, are heavier than air and can collect in low lying or sealed areas creating oxygen-deficient pockets within the work place. Use inert atmospheres only in large work places with good ventilation. Do not breathe in or enter an inert atmosphere piece of equipment until it has been thoroughly purged with air.
- 2-4.3** Heat processing equipment must always be used with caution. Proper equipment such as insulated gloves, safety goggles and tongs should be used for reaching into hot equipment. Proper supervision is essential and only trained personnel should be allowed to operate the furnace.
- Always remember you are working with elevated temperatures.
- Do not touch surfaces - they could be hot and burns could result.
 - Do not breathe hot furnace air. Heated air could burn lungs.
 - Many items become dangerous when heat is applied. Explosion or fire could result. Make sure you know what you are putting in the furnace can be heated safely at the furnace operating temperature.
- 2-4.4** Furnace heating elements operate at line voltage. Do not touch them or allow work to come in contact with the heating elements. A door heating element interlock is provided to disconnect power from heating elements when the door is opened. Do not defeat the operation of this door interlock.
- 2-5.5** Disconnect power before servicing equipment. Furnaces operate under high voltage and electrical shock is possible. Proper panel lockout procedures should be followed.
- 2-4.6** Disconnect other sources of potential energy such as compressed air, before servicing. Proper lockout procedures should be followed.
- 2-4.7** Do not operate mechanical or electrical equipment with guards removed. Operating with guards removed could result in bodily injury.
- 2-4.8** Furnaces with vertical lift doors or top loading doors must be blocked open before passing beneath them. A falling door may cause bodily injury. A safety pin, latch or support strut is provided for this purpose.

2-5 MAINTENANCE AND INSPECTION

- 2-5.1** Regularly scheduled inspection and maintenance of all safety devices shall be performed by user. Failure to do this may result not only in fire or explosion damage, but also contribute to accidental shutdowns and loss of production. See Section 7 - Maintenance and Appendix C - Minimum Periodic Maintenance Report.
- 2-5.2** Regularly scheduled inspection of the furnace interior, heat chamber and ductwork shall be performed by user to determine need for cleaning and repair. Failure to do this may result in internal fires or component failure resulting in furnace damage and loss of production.
- 2-5.3** It shall be the sole responsibility of the user to establish, schedule and enforce the frequency of and the extent of the inspection/maintenance program (as well as the corrective action to be taken) because only the user can know what the actual operating conditions are. Contact your insurance authority, Factory Mutual or the National Fire Protection Association, whose addresses are listed in Appendix B, for more information on inspection/maintenance programs.

2-5.4 It shall be the responsibility of the end user to determine that current processing is within the scope of the original design of the equipment.

2-6 RETROACTIVITY

This equipment has been designed and manufactured in accordance with applicable National Codes in effect as of the date of manufacture. It is the responsibility of the end user to update equipment as necessary to comply with future code changes. If you are in doubt, contact manufacturer to review your equipment design against current National Codes.

3 INSTALLATION

3-1 LOCATION

- 3-1.1** Furnaces shall be located to protect them from damage by external heat, vibration and mechanical hazards.
- 3-1.2** Furnaces shall be located to make maximum use of natural ventilation, to minimize restrictions to adequate explosion relief, and to provide sufficient air supply for personnel. Room volume should be at least 10 times the furnace volume.
- 3-1.3** Furnaces shall be located to minimize exposure to power equipment, process equipment and sprinkler risers. Unrelated stock and combustible materials shall be maintained at a fire-safe distance but not less than 10 feet from a furnace, a furnace heater or ductwork.
- 3-1.4** Furnaces shall be located to minimize exposure to people from the possibility of injury from fire, explosion, asphyxiation, and hazardous materials and shall not obstruct personnel travel to exit ways.
- 3-1.5** If the furnace control panel is located away from the furnace, operators must be allowed access to the control panel and/or main disconnect to allow them to shut down the furnace in an emergency.
- 3-1.6** Furnaces shall be located to prevent an ignition source to flammable coating dip tanks, spray booths and storage and mixing rooms for flammable liquids and to prevent exposure to flammable vapor or combustible dust clouds. Furnaces should not be located in hazardous (classified) locations unless they are designed to comply with the applicable requirements of NFPA 70 National Electric Code (see Appendix B).
- 3-1.7** Equipment shall be protected from corrosive external processes and environments, including fumes or materials from adjacent processes or equipment that produces corrosive conditions when introduced into the furnace environment.
- 3-1.8** The furnace is not intended for outdoor installation and must be sheltered from weather. Unheated shelters may result in non-uniform temperatures or insufficient heat to attain maximum operating temperature. Condensation may also occur which would be detrimental to the steel structure and electrical components.
- 3-1.9** Suitable portable fire extinguishers should be available and operators trained in their use. All such fire protection equipment should be inspected periodically in accordance with appropriate standards. Reference NFPA 10 Standard for Portable Fire Extinguishers (see Appendix B).

3-2 BUILDING CONSIDERATIONS

- 3-2.1** When selecting the location for a furnace, consideration must be given to the possibility of fire, building damage and personal injury. Hazards to be considered include overheating of material in the furnace and escape of fuel gas or exhaust into the work place.
- 3-2.2** Furnaces shall be located and erected so that the building structural members are not affected adversely by the maximum anticipated temperature or by the additional loading caused by the furnace and load.
- 3-2.3** Furnaces should be placed on noncombustible floors or on structures approved for use over combustible floors such as concrete floor slabs or hollow tiles.

- 3-2.4 Level the furnace using shims, if necessary. Where mounting holes are provided, anchor the furnace securely. Shims should be permanently mounted to the furnace after installation.

3-3 CLEARANCES

- 3-3.1 Furnaces shall be located with adequate space above and on all sides to allow for inspection, maintenance and operator access. Provisions also shall be included for unobstructed discharge of building sprinklers, the installation of automatic fire protection system within the furnace, if necessary and the proper functioning of explosion relief doors and panels.
- 3-3.2 Do not place the furnace up against a wall. A minimum air space of 12 inches must be provided on all sides to allow for air circulation, with additional space being provided for furnaces operating over 1400°F (760°C) to keep temperature at adjacent structures and materials below 160°F (70°C). Local, city and state codes may specify building requirements and special provisions for locating furnaces.
- 3-3.3 The furnace should be located so there is unrestricted air circulation around all motors for proper cooling.
- 3-3.4 Do not store material on top of furnace. The furnace is not designed to support external loads and material may get hot, ignite and cause a fire.
- 3-3.5 To prevent ignition of combustible material, combustible material shall be located at a safe distance from furnace and furnace ductwork. The National Fire Protection Association (NFPA) Standard 86 specifies a minimum distance of 2-1/2 feet; Factory Mutual (FM) specifies at least 10 feet.
- 3-3.6 The furnace door travel must not be restricted and should face away from main aisles, work areas and automatic sprinkler risers, feeds and cross mains.

3-4 VENTILATION

- 3-4.1 Where furnaces are located in basements or enclosed areas, sufficient room ventilation shall be supplied to provide required combustion air for fuel fired equipment and to prevent the hazardous accumulation of vapors from processing.
- 3-4.2 Furnaces designed for use with fuel gas or process gas having a specific gravity greater than air (such as propane) shall be located at or above grade and shall be located to prevent the escape of the fuel gas from accumulating in basements, pits, or other areas below the furnace.
- 3-4.3 Fresh air inlets and exhaust outlets (if applicable) must never be restricted. If filtered air is provided, there must be adequate filter capacity to prevent any reduction in airflow even under adverse loading of the filter. The filters must be periodically inspected and replaced as required.
- 3-4.4 A sufficient quantity of building make-up air should be admitted to furnace rooms and buildings to provide the air volume required for furnace safety ventilation and adequate combustion air for fuel fired equipment. Buildings should not operate under a negative pressure.

3-4.5 Some furnaces are equipped with an exhaust outlet. This outlet must be vented by an exhaust flue to an exhaust stack for discharge to an outside location, in accordance with local codes and requirements. Do not connect exhaust outlet directly to exhaust stack. Exhaust gas temperature is the same as internal furnace temperature. Reduce exhaust temperatures by diluting with room air before ducting to the outside. Caution must be taken to protect combustible building materials from coming in contact with the hot exhaust stack.

3-4.6 The minimum safe exhaust rate must be confirmed for furnaces equipped with a powered forced exhauster to handle flammable solvent vapors or products of combustion from fuel fired equipment. The exhaust rate has been set at the factory and dampers cut off and screwed in place or in some other manner limited to prevent exhaust rate from being reduced below safe minimum exhaust rate.

After installation, this exhaust rate must be confirmed. This must be done at the outlet of the stack from the building. The exhaust rate must meet or exceed the minimum rate indicated on the Safety Design Form located on the side of the furnace. If it is necessary to open the exhaust damper to increase the exhaust rate, it must be cutoff or locked in position to prevent accidental closing.

Exhaust rate must be checked again if any changes are made to ventilation system, duct work or building ventilation. Adding additional equipment, which requires ventilation, to the building will require additional make-up air to the building to prevent the building from operating under negative pressure. Operating building under negative pressure will reduce exhaust rate from furnace to below safe minimum exhaust rate.

Fuel fired furnaces without powered forced exhauster must have unrestricted negative pressure (room not under negative pressure) stack to remove products of combustion from work area.

3-4.7 For additional ventilation information, refer to NFPA 31 Standard for the Installation of Oil-Burning Equipment, NFPA 54 National Fuel Gas Code and NFPA 91 Standard for Exhaust systems for Air Conveying of Vapors, Gases, Mists and Noncombustible Particulate Solids (see Appendix B).

3-5 EXHAUST DUCTWORK

3-5.1 Wherever furnace ducts or stacks pass through combustible walls, floors, or roof, either non-combustible insulation or clearance, or both, shall be provided to prevent combustible surface temperatures from exceeding 160°F (72EC).

3-5.2 Where ducts pass through non-combustible walls, floors or partitions, the space around the duct shall be sealed with non-combustible material to maintain the fire rating of the barrier. Ducts that pass through fire walls should be avoided. Local, city and state codes may apply to duct installation.

3-5.3 Exhausts systems should be installed in accordance with Chapter 1, 2 and 3 of NFPA 91 Standard for Exhaust Systems for Air Conveying of Vapors, Gases, Mists, and Noncombustible Particulate Solids (see Appendix B).

3-5.4 Ducts shall be constructed entirely of sheet steel or other non-combustible material capable of meeting the intended installation and conditions of service. The installation shall be of adequate strength and rigidity and shall be protected where subject to physical damage.

- 3-5.5** Ducts handling fumes that leave a combustible deposit shall be provided with clean-out doors and such doors should be equipped with tight fitting doors or covers. It is important that furnaces and ducts be kept clean if they are subjected to a build-up of flammable deposits of condensed solvent, oil vapors, dust or other combustible debris. The build-up of condensed vapors or combustible debris is a major cause of fires. Frequency of cleaning should be based on never allowing build-up to exceed 1/8" thickness in any location.
- 3-5.6** No portions of the building shall be used as an integral part of the duct.
- 3-5.7** All ducts shall be made tight throughout and shall have no openings other than those required for the operation and maintenance of the system. All interior laps in the duct joints should be made in the direction of the flow.
- 3-5.8** All ducts shall be thoroughly braced where required and substantially supported by metal hangers or brackets.
- 3-5.9** Ducts handling flammable vapors shall be designed to minimize the condensation of the vapors out of the exhaust stream onto the surface of the ducts. One method is to insulate the ducts. If flammable condensation cannot be avoided, ducts should be pitched to drain to suitable traps or other safe locations.
- 3-5.10** Ducts handling combustible solids shall be designed to minimize the accumulation of solids within the ducts.
- 3-5.11** Exhaust ducts that will contain combustible deposits of any type require automatic sprinklers in accordance with NFPA 13 Standard for Installation of Sprinkler Systems (see Appendix B).
- 3-5.12** Exhaust ducts shall not discharge near building openings or other air intakes that allow re-entry of effluents into the building.
- 3-5.13** Clearance between metal ducts and stored combustible material should be at least 2-1/2 feet. Guards should be installed to assure this clearance.
- 3-5.14** Multiple exhaust fans manifolded together should have manifold designed so that operation of one or more exhaust fan does not create a hazard such as back flow to an idle furnace or reduced exhaust flow due to increased manifold pressure.
- 3-5.15** Duct work should not include dampers that could be closed and restrict flow within the duct work.

3-6 FUEL GAS SUPPLY

- 3-6.1** Piping from the point of delivery to the equipment should comply with NFPA 54, National Fuel Gas Code. Local, city and state codes should be followed. Gas source pressure must be less than 60 psig.
- 3-6.2** A gas filter or strainer and sediment trap with vertical leg (drip leg) at least 3 pipe diameters long (3 inch minimum) of same size as supply piping, shall be installed in the fuel gas supply piping to protect the downstream safety shutoff valves and regulator from materials that could interfere with their operation.

- 3-6.3** All gas heated equipment shall be provided with an individual gas pressure regulator properly sized to supply the pressure and volume required. The furnace nameplate lists the gas pressure and the burner capacity. Gas pressure regulator should have the following characteristics:
- The regulator must be of the full lock-up type; gas pressure must be regulated even under no flow condition.
 - Incoming pipe size should not exceed 2" diameter.
 - Self contained with no external static or control piping.
 - Single port with correctly sized orifice for the maximum gas pressure at the regulator inlet.
 - Valve seat is of resilient material designed to withstand abrasion of gas, impurity in gas, cutting by the valve and to resist permanent deformation by the valve port.
 - Capable of regulating downstream pressure under no flow conditions to not more than 150 percent of the discharge pressure under flow conditions.
- If these criteria are not met, a pressure relieving or limiting device is required as outlined in the NFPA 54 National Fuel Gas Code.

- 3-6.4** Over pressure protection is required in addition to gas regulator if:
- Regulator supply pressure exceeds maximum operating pressure rating of any downstream component.
 - Failure of a single upstream line regulator or service pressure regulator results in a supply pressure exceeding maximum operating pressure rating of any downstream component.

- 3-6.5** Over pressure protection shall be provided by one of the following:
- Additional pressure regulator installed in series with line or service pressure regulator.
 - A monitoring regulator installed in combination with line or service regulator.
 - A full capacity pressure relief valve.
 - An over pressure cut-off device such as a slam shut valve or a high-pressure switch in combination with a rated shut-off valve.

Refer to NFPA 54 National Fuel Gas Code for clarification.

- 3-6.6** A remotely located emergency manual shutoff valve shall be provided to allow the fuel to be turned off in an emergency and shall be located so that fire or explosion at the furnace does not prevent access to this valve. Operators should be instructed on the location of this valve and allowed access to shut off fuel flow in an emergency. Valve shall have permanently affixed visual indication of position and be operable without tools.
- 3-6.7** An equipment isolation shutoff valve must be provided at each piece of equipment. Valve shall be quarter turn with stop, permanently affixed visual indication of position, and operable without tools. Valve handle must remain affixed and be parallel to pipe when open and perpendicular to pipe when closed.
- 3-6.8** Regulators and high or low gas pressure switch vent lines shall be piped to a safe location outside the building according to local codes. Protect outlet from water entry and provide bug screen.
- 3-6.9** Vent lines from regulator and switches of a single furnace may be manifolded together in such a manner that diaphragm rupture of one regulator or switch does not back load others. Cross-sectional area of manifold shall not be less than the greater of either
- cross-sectional area of largest vent line plus 50%, or
 - sum of cross-sectional area of two largest vent lines

3-6.10 Vent lines from multiple furnaces shall not be manifolded together.

3-6.11 A normally open vent valve between safety valves shall not be combined with other vents. Care must be taken to terminate a vent valve line in a safe approved location.

3-7 ELECTRICAL

3-7.1 All electrical connections should be made in accordance with the appropriate local and national codes. Refer to NFPA 70 -- National Electric Code. (See Appendix B)

3-7.2 Properly size the electrical supply using information provided on the furnace nameplate. Electric supply must include a safety shut off such as a circuit breaker or fused disconnect switch between your power supply and the equipment.

3-7.3 The furnace must be adequately grounded. Grounding wire must be sized in accordance with local codes. Where more strict codes do not exist, refer to the National Electrical Code - NFPA 70. A grounding lug has been provided near the power input terminals.

3.7.4 Care must be taken during installation of electrical service to the control panel that metal chips or filings do not get into electrical components. Cover components when drilling or cutting control panel.

4 PRIOR TO PLACING THE FURNACE IN SERVICE

- 4-1 Read instruction manual completely. Additional copies of the Operating Instructions have been provided in plastic covers for posting at the furnace.
- 4-2 All furnaces should be dried out before heating to maximum temperature. See specific drying schedule included in your Operating Manual or follow the general procedure below. Ceramic hearth trays should be installed prior to dry-out.

INSULATION DRY-OUT SCHEDULE

All furnaces will produce smoke and odors when first heated. The smoke and odors come from three sources:

- 1) Surfaces that have been painted after test;
- 2) Binders that remain in the insulation;
- 3) Moisture that has been absorbed by the insulation.

If during the initial run of the furnace the smoke and odors become objectionable, set the temperature at 300°F and allow the furnace to remain at 300°F until the smoke is no longer generated. Increase the temperature in steps until you've reached the maximum operating temperature. It may take several days of running at the maximum operating temperature to eliminate all smoke and odors.

If the furnace is not heated for an extended time period, moisture may accumulate in the insulation. When heated, this moisture will be driven out and the above process may have to be repeated.

The following procedure **must** be followed prior to placing your furnace in operation:

-After the furnace has been installed, it is ready for initial dry out. Before the equipment can be put into operation, the refractories must be **slowly** dried out. The furnace refractories absorb moisture; if they are heated rapidly, steam will be generated which can damage the refractories. This is true on initial start-up and after any prolonged shutdown.

-During initial dry out, organic binders contained in some insulating materials will burn out. The furnace door must be left slightly open to allow air to enter the work chamber during dry out to allow these binders to burn out. This will avoid the formation of carbon deposits in the insulation which could lead to premature heater terminal failure.

-It is necessary to open the furnace door slightly to allow the moisture and organic binders to escape. Only a small opening is required. If the door is opened too far, the door switch will turn off the power to the heating elements.

-If at any of the dry out stages, smoke and moisture continue after the hold period, continue holding until they stop.

FIRST DAY:

1. With the furnace door slightly open, set the temperature control at 500°F and hold for two (2) hours or until smoke and moisture no longer escape from the open door.
2. Increase the temperature to 750°F and hold for four (4) hours or until smoke and moisture no longer escape from the open door.

3. Increase the temperature to 900°F and hold for two (2) hours or until smoke and moisture no longer escape from the open door.
4. Turn off the furnace and allow it to sit overnight with the door slightly open.

SECOND DAY:

1. With the furnace door slightly open, heat the furnace again to 900°F and hold for two (2) hours or until smoke and moisture no longer escape from the open door.
 2. Increase to 1200°F and hold for two (2) hours or until smoke and moisture no longer escape from the open door.
 3. If the furnaces= maximum temperature is 1200°F, hold at 1200°F for two (2) additional hours or until smoke and moisture no longer escape from the open door.
 4. Increase to 1600°F and hold for 2 hour. Close the furnace door and continue at 1600°F for 1-1/2 hours. At the end of this time period, increase to the maximum operating temperature anticipated and hold for two (2) hours. If no higher operating temperature is anticipated, continue to run at 1600°F for two (2) hours or until smoke and moisture no longer escape from the open door.
- 4-3** The excess temperature limit interlock should be connected to your alarm system. The wiring schematic indicates where the alarm relay should be located for this alarm circuit.
- 4-4** After the installation is completed, replace all doors, covers and guards that had been removed for shipment or installation. At no time should equipment be operated if covers or guards are open, removed or partially closed.
- 4-5** When the equipment is placed in operation, check all blowers for proper rotation. Rotation directional arrows are located near each blower. Three phase motors may be reversed by interchanging any two (2) of the three (3) wires which supply power to the furnace. Do not switch leads at the motor starter or motor. Single phase motors are correctly set at the factory but correct rotation should still be confirmed.
- 4-6** The exhaust rate must be checked on furnaces equipped with a powered forced exhauster to handle flammable solvent vapors or products of combustion from gas heated equipment. This must be done at the outlet of the stack from the building with all dampers in minimum position. It must meet or exceed the minimum rate indicated on the Furnace Safety Design Data Form located on the side of the furnace. If it is necessary to open the exhaust damper to increase the exhaust rate, it must be cutoff or locked in position to prevent accidental closing.
- 4-7** Check incoming voltage against that shown on the nameplate.
- 4-8** Check operating current against the amperage shown on the nameplate.
- 4-9** On gas heated equipment, purge gas line to furnace of all air. While purging gas line of air, purged gas must be vented to an approved location outside the building.
- 4-10** Check gas pressure against that shown on the furnace nameplate.
- 4-11** Tighten all terminals, especially on power connections, to minimize terminal and component failure due to poor contact. Connections should be checked periodically for tightness and signs of overheating.

4-12 Commissioning is required prior to releasing equipment for production. The party responsible shall insure that installation is complete and done correctly. Safety systems should be tested and operators trained. At the time of commissioning, the first Periodic Maintenance Inspection should be performed to familiarize personnel with the equipment. See Section 5 - PROCESSING and Section 7 - MAINTENANCE.

4-12.1 Setpoints of all safety interlocks shall be documented for future reference.

4-12.2 Supply piping fuel shall be checked for leaks.

4-12.3 Personnel operating, maintaining or supervising shall be instructed and trained in their job functions and be required to demonstrate an understanding of the equipment, its operation and safe operating procedures including emergency shutdown.

4-12.4 Equipment shall be operated in accordance with original design parameters.

4-12.5 Personnel operating, maintaining or supervising shall be informed of the danger of removing, or rendering ineffective, safety devices.

5 PROCESSING

5-1 DO NOT LEAVE THIS EQUIPMENT IN OPERATION UNATTENDED

When using any heat processing equipment there is always the risk of overheating due to a component malfunction. A trained operator should always be present. If this is not possible, the furnace should be located where overheating will not cause damage to the building, adjacent stock or endanger personnel. Special consideration should be made for the potential of smoke damage should a fire ensue. Fire suppression equipment should be installed to protect the furnace and building. The excess temperature limit interlock should be connected to the building alarm system.

5-2 For start-up, emergency shut down and operation of optional equipment, refer to the specific Operating Instructions for your equipment located elsewhere in the manual. A second set of these specific Operating Instructions are provided for posting at the furnace for the operator.

5-3 When loading a furnace care must be taken to avoid touching or insulating the thermocouple or temperature sensor. Free air movement around this sensor is essential for safe and correct temperature control.

5-4 The excess temperature limit interlock should be set slightly above the operating temperature to protect the workload. Overheating of material is a major cause of fire loss. Excess temperature limit interlock should indicate in the same temperature units (°F or °C) as the main controller.

5-5 An alarm should be installed that will sound upon the excess temperature limit interlock being activated. This alarm should be installed in an area where it will attract the attention of plant personnel properly trained to take corrective action. The wiring schematic provided in this manual indicates where the alarm relay should be located for this alarm circuit.

5-6 Furnaces handling flammable solvents and fuel fired furnaces have a minimum safe exhaust rate. These furnaces have cut off dampers on fresh air and exhaust. Do not close the fresh air or exhaust beyond these settings.

5-7 Furnaces that are designed for flammable solvent processing and/or are fuel fired, include a purge timer. This timer is factory set based upon a specific application. DO NOT change the purge timer setting. Purge time is calculated to exhaust four (4) furnace volumes of fresh air prior to allowing the heat to be turned on. Reducing purge time could result in failure to remove combustible vapors from furnace before heat is turned on. This could result in an explosion and fire. A caution nameplate is located next to the purge timer indicating the correct setting.

5-8 Do not overload the furnace. Air circulation and shadowing by other parts is very important to the proper operation of a furnace.

5-8.1 Leave space between articles on each shelf (if so equipped) to allow air to move between parts and prevent parts from shadowing each other.

5-8.2 Parts should be uniformly distributed on the furnace hearth to prevent hot or cold spots.

- 5-9** For Tempering Furnaces, open the exhaust and fresh air dampers enough to prevent fouling of the work. Where significant amounts of smoke or moisture are being driven off in the furnace process, it is necessary to exhaust enough air to remove this material. Failure to provide sufficient ventilation may result in condensation of oil or solvent vapors inside furnace walls with a resulting risk of fire.
- 5-9.1** When the exhaust is increased, the fresh air intake must also be increased. Failure to do this will result in cold spots within the furnace, particularly around the door, since air will be drawn in past the gaskets. When the fresh air intake damper is properly adjusted, there will be a slight leaking of hot air out of the door gaskets. The fresh air intake damper is located on the wall of the heat chamber.
- 5-9.2** Proper balance of the fresh air inlet and exhaust outlet are essential for uniform air temperature. Room air entering the fresh air inlet expands when heated and pressurizes the work space forcing air out the exhaust or past the door gasket. Too much fresh air (or too little exhaust) can result in excessive leakage of hot air at the door seal.
- 5-9.3** Tempering furnaces are equipped with louvered ductwork. The louvers may be adjusted to give the best performance for your particular process. The louvers were originally set at the factory in an empty furnace. Loading of your parts may affect uniformity. These louvers are not designed for frequent adjustment and should only be changed when absolutely necessary. Louvers should be opened where the work space is cold and closed where it is hot.
- 5-10** Hot loads, tongs and other hot tools or fixtures such as shelves and loading trucks should be located in areas clearly marked to warn plant personnel of the potential danger of burns or fires caused by the hot parts.
- 5-11** Furnace blowers are either water or air cooled. Cooling must continue whenever furnace is heated. Do not stop cooling water or stop air cooled blower when furnace is above room temperature or this will cause blower bearings to be damaged. Incoming cooling water should be clean and not exceed 85°F. The water temperature rise through the motor should not exceed 15°F. Pressure relief (75 Psi maximum relief pressure) must be provided in closed water system to prevent explosive rupture of cooling chamber on motor if water flow fails. Water cooled motors cannot operate in areas where temperatures may be below freezing or water may freeze. Review vendor blower operating instructions for specific information regarding blower.
- 5-12** Furnace blowers cannot be stopped and restarted when furnace is hot. Once heated, the blower will not be strong enough to take the sudden torque of restarting. Read vendor blower operating instructions for specific information regarding blower.

6 SAFETY EQUIPMENT

- 6.1** Practically all explosions and fires in furnaces can be traced back to human error. It should be noted that:
- 6-1.1** For the protection of personnel and property, careful consideration should be given to the supervision and monitoring of conditions that could cause, or could lead to, a real or potential hazard on any installation.
 - 6-1.2** The presence of safety equipment on an installation cannot, in itself, ensure absolute safety of operation.
 - 6-1.3** There is no substitute for a diligent, capable, well-trained operator.
 - 6-1.4** Highly repetitive operational cycling of any safety device can reduce its life span.
- 6-2** Electric relays and safety shutoff valves should not be used as substitutes for electrical disconnects and manual shutoff valves.
- 6-3** Regularly scheduled inspection, testing, and maintenance of all safety devices shall be performed. (See Section 7 - MAINTENANCE and Appendix C - MINIMUM PERIODIC MAINTENANCE REPORT)
- 6-4** Safety devices shall not be removed or rendered ineffective by bypassing them electrically or mechanically.
- 6-5** Minimum safety equipment recommended. Additional safety equipment may be required for particular applications: (See Appendix A - SAFETY EQUIPMENT, DESCRIPTION & OPERATION)
- 6-5.1** For electric furnaces:
 - manual reset excess temperature limit interlock
 - separate heating element control contactors
 - door heating element interlock
 - 6-5.2** For gas heated furnaces:
 - manual reset excess temperature limit interlock
 - exhauster airflow switch (if so equipped)
 - purge timer
 - combustion air flow switch
 - high gas pressure switch
 - low gas pressure switch
 - two (2) main safety shut off valves and test stations
 - two (2) pilot safety shut off valves and test stations
- 6.6** No matter how much safety equipment is provided on the furnace, it cannot protect the operator, other personnel or property from unsafe conditions caused by poor judgement or misapplication. Common sense must be used for safe operation. If in doubt, contact the factory. Check the process periodically to ensure furnace is being used as originally intended.

7 MAINTENANCE

- 7-1** For safe furnace operation, a preventive maintenance program must be developed and followed for each individual furnace application. The user should review recommendations from their insurance underwriters. We suggest the review of Factory Mutual (FM) Specification 6-9 on Industrial Ovens and Dryers and the National Fire Protection Association (NFPA) Specification 86 on Ovens and Furnaces. We also recommend a Maintenance Report be developed which lists tests and inspections performed. A copy of this report should be kept on file for future review.

A Minimum Periodic Maintenance Report is provided in Appendix C as an example for developing your own periodic maintenance schedule and report.

Regularly scheduled inspection and maintenance of all safety devices shall be performed by the user to ensure proper function. At a minimum, the unit should be fully inspected annually. This interval should be shortened for units operating more than 40 hours per week or when previous inspections have shown a need for more frequent inspections.

- 7-2** When cleaning the inside of furnaces, changing heating elements, repairing insulation or performing any task that produces dust from the refractory materials (brick and aluminum silica fiber) that make up the insulation, the following precautions should be followed:

- 1) Use a NIOSH or MSKA approved high efficiency respirator mask (3M 8710 or equivalent).
- 2) Use goggles or safety glasses with side shields; do not wear contact lenses.
- 3) Use leather gloves, long-sleeved and long-legged, loose fitting clothing.
- 4) Handle materials in a manner that will create the least amount of dust.
- 5) Wash exposed skin areas gently with soap and warm water after handling refractory materials.
- 6) Consult the MSDS information on the materials involved included elsewhere in this manual.

- 7-3** Disconnect fuel, electric power, steam, compressed air and any other energy source before servicing equipment. Furnaces operate under high voltage and electrical shock is possible. Proper OSHA required lockout procedures should be followed.

- 7-4** Furnace heating elements operate at line voltage. Do not touch them or allow work to come in contact with the heating elements. A door heating element interlock is provided to disconnect power from heating elements when the door is opened. Do not defeat the operation of this door interlock.

- 7-5** Furnaces with vertical lift doors or top loading doors must be blocked open before entering. Falling door may cause bodily injury. A safety pin, latch or support strut is provided for this purpose.

- 7-6** Do not operate mechanical or electrical equipment with guards removed. Operating with guards removed could result in bodily injury.

- 7-7** The furnace work space or heat chamber may constitute a confined space as defined by OSHA. If so, comply with OSHA confined space hazard requirement (ANSI Z117-1).

7-8 **RECOMMENDED MAINTENANCE ITEMS:**

It shall be the sole responsibility of the user to establish, schedule and enforce the frequency of and the extent of the inspection/maintenance program (as well as the corrective action to be taken) because only the user can know what the actual operating conditions are. Personnel who are familiar with the equipment should make the tests. It is usually better that maintenance personnel from mechanical and electrical departments check the equipment rather than regular furnace operators. These observers may catch things that may be otherwise overlooked.

The following are minimum maintenance items we recommend be covered. Your list will vary depending upon the specific furnace and operating conditions.

7-8.1 Application

7-8.1.1 The user is responsible to ensure that the furnace process has not changed from the conditions for which it was designed and that the furnace is not modified. Specifically, it must be ensured that the design exhaust rate is obtained, and that amount of flammable solvents placed in the furnace (if applicable) and the operating temperature does not exceed the design capacity.

7-8.2 Electrical

7-8.2.1 Periodically tighten all terminals, especially on power connections, to minimize terminal and component failure due to poor contact.

7-8.2.2 Periodically inspect contacts in contactors, relays, motor starters, etc., for signs of wear or sticking.

7-8.3 Furnace Body

7-8.3.1 The exterior of the furnace should be touched up whenever scratches occur to prevent rusting.

7-8.3.2 Do not allow accumulation of combustible material or other foreign matter in the work space, heat chamber (including heating element surfaces) duct work, air inlets, exhaust outlets, filters, control enclosures, motors, safety switches, door latches, and door hinges. Care must be taken in cleaning any combustible build-up to avoid creating a source of ignition (spark). Scraping with non-sparking tools or melting with steam is suggested. Lint and dust should be removed by vacuum cleaning. Blowing with compressed air or steam should be avoided if there is a possibility of explosion from a combustible dust cloud.

7-8.3.3 Do not allow accumulation of combustible material on work holders, drip pans or on or beneath floor (hearth) of furnace.

7-8.3.4 Temperature control and excess temperature limit interlock thermocouples must be inspected periodically for damage. Location of the thermocouples cannot be changed. Thermocouples must be located in free air not touching any portion of furnace body, load handling material such as spacers or racks, or the work load.

7-8.3.5 Furnace repair by cutting, welding or any other method that could produce a source of ignition (spark) should be avoided and only then after all combustible deposits or debris have been removed.

7-8.3.6 When cleaning the inside of furnaces, changing heating elements, repairing insulation or performing any task that produces dust from the refractory materials that make up the insulation, the following precautions should be followed:

- 1) Use a NIOSH approved respirator.
- 2) Use goggles or safety glasses with side shields
- 3) Use leather gloves, long-sleeved and long-legged, loose fitting clothing.
- 4) Handle materials in a manner that will create the least amount of dust.
- 5) Consult the MSDS information on the materials involved included elsewhere in this manual.

7-8.4 Duct Work

- 7-8.4.1** It is important furnace ducts be kept clean. If they are subjected to a build-up of flammable deposits of condensed solvent, oil vapors, dust or other combustible debris they must be periodically cleaned. The build-up of condensed vapors or combustible debris is a major cause of fires. Cleaning frequency should be determined by furnace process requirements.

7-8.5 Lubrication

- 7-8.5.1** Electric motors having oil holes require lubrication after every 25,000 hours or 3 years of light duty operation. Use a good grade of SAE 10 electric motor oil or as recommended by the manufacturer of the motor. Larger motors in the integral horse power range, which require grease, should be greased every six (6) months or more frequently where the severity of the service would dictate. No special heat resistant grease is necessary.
- 7-8.5.2** All bearings, including those on blowers, exhaustor or conveyor system, should be greased every six (6) months or 500 hours of operation with a good grade of machine grease. No special heat resistant grease is necessary.

7-8.6 Doors/Gaskets

- 7-8.6.1** The furnace door should be inspected regularly to see that it is being held firmly and uniformly against the furnace front plate providing a maximum sealing force. Slots in the mounting brackets and/or adjusting screws are available for this purpose. **NOTICE:** Before attempting these adjustments, be sure the furnace is level. If the furnace is not on a solid level base, it could twist out of square resulting in a poor seal, which cannot be corrected by an adjustment.
- 7-8.6.2** The door should be inspected for damage which would allow excessive leakage of hot air. The gasket (if so equipped) or door seal should be replaced when damaged or when an adequate seal cannot be maintained.

7-8.7 Blowers and Exhausters

- 7-8.7.1** Tighten set screws between bearings and shaft before operating and check periodically. Loose bearings will allow shaft movement resulting in wear to the shaft within the bearing race. Set screws on blower wheels must also be checked and tightened.
- 7-8.7.2** Recirculation and exhaust blowers that are V-belt driven shall be checked for sheave alignment to prevent excessive belt wear and to make sure belts are not slipping.
- 7-8.7.3** Inspect to make sure all blowers, exhausters and other fans are rotating in the correct direction. Refer to Section 4-5 for changing rotation.
- 7-8.7.4** Periodically inspect and clean blower and exhauster wheels to remove any build up of deposits on the blade surfaces. Accumulation of deposits could possibly reduce volume of air flow and cause a dangerous reduction in safety ventilation.
- 7-8.7.5** Air flow test should be conducted on the exhaust flow under furnace operating conditions, with volume controls at their minimum settings, to ensure that the safety ventilation required is achieved. Reference Safety Design Form for required ventilating. See Section 8 - TROUBLE SHOOTING for inadequate ventilation symptoms.

7-8.8 Electric Furnaces

- 7-8.8.1** Temperature controller should cycle main contactor(s), or SCR power controller, only. Separate (back-up) contactor(s) should not cycle.
- 7-8.8.2** Excess temperature limit interlocks, door heating element interlocks and all other safety switches should open both main contactor(s), or SCR power controller, and separate (back-up) contactor(s).
- 7-8.8.3** Inspect heating elements for contamination, distortion and adequate support.
- 7-8.8.4** Check electrical heating element connections at terminals for tightness.

7-8.9 Fuel Gas Furnaces

- 7-8.9.1** Check main safety shut off valves for leakage. (See Appendix D - Main Safety Shutoff Valve Leak Test Procedure)
- 7-7.9.2** Check pilot safety shut off valves for leakage. (See Appendix D - Pilot Safety Shutoff Valve Leak Test Procedure)
- 7-8.9.3** Check that vent valve is closed when main burner is firing. (Note: Vent valve is only installed by specific request of customer.)
- 7-8.9.4** With pilot burner lit, check low gas pressure switch setting by turning gas pressure switch setting up until pilot is shutdown. Reset to original setting as indicated on electrical wiring diagram.
- 7-8.9.5** With main burner firing, check high gas pressure switch by turning gas pressure switch setting down until burner is shutdown. Reset to original setting as indicated on electrical wiring diagram.
- 7-8.9.6** Lubricate gas cocks and operate to confirm free movement.
- 7-8.9.7** Locate remote emergency valve, lubricate and operate to confirm free movement.
- 7-8.9.8** Safety valves should be replaced when the number of safety valve cycles reaches 90% of lifetime cycle rating. Number of cycles can be estimated by multiplying years of service by 260 work days per year (5 day work week) and the number of times furnace is turned on and off per day. Lifetime cycle rating for valves is at least 1 million cycles. Replace valves if estimated number of cycles exceeds 900,000.
- 7-8.9.9** Check that pilot and main burner lights easily and that flame appears blue with yellow tips.
- 7-8.9.10** Check gas pressure against furnace nameplate and adjust as necessary.
- 7-8.9.11** Inspect flame rod; clean and reposition as necessary.
- 7-8.9.12** Inspect control valve linkage to motor operator for free and smooth operation.
- 7-8.9.13** Test burner management system (flame safety relay) by closing main burner gas cock and pilot burner gas cock causing flame relay to shut down burner by closing both safety valves and both pilot valves.

7-8.10 Safety Switches

- 7-8.10.1** Check door heating element interlock to make sure electric power is removed from heating element as door is opened.
- 7-8.10.2** Check each air flow safety switch operation by disconnecting both of the air tubes from each air flow switch to make sure furnace heat is shutdown.
- 7-8.10.3** Check purge timer setting against Safety Design Form. Check purge time against a clock to check timing operation.

7-8.11 Temperature Controls

- 7-8.11.1** Heat furnace to operating temperature and check furnace temperature at control point against a separate reliable temperature indicator to make sure temperature controller calibration is correct.
- 7-8.11.2** Heat furnace above setting of excess temperature limit interlock and make sure excess temperature limit interlock shuts down furnace heat.
- 7-8.11.3** Disconnect one side of thermocouple connection to confirm upscale break protection is operative on both the main controller and the excess temperature limit interlock.

7-8.12 Location

- 7-8.12.1** The user is responsible to determine that facility changes in the vicinity of the furnace have not created a hazardous condition. Specifically, the furnace should be protected from external heat, vibration, mechanical hazards and corrosive environment.
- 7-8.12.2** Processes involving flammable liquids or creating explosive vapor or combustible dust clouds must not be located near the furnace.
- 7-8.12.3** Portable fire extinguishers located in the vicinity of the furnace must be inspected periodically.
- 7-8.12.4** Fire suppression system installed in the furnace should be periodically tested. All sprinkler heads in the furnace and duct work should be periodically inspected and cleaned.

8 TROUBLESHOOTING

8-1 NO HEAT

8-1.1 Air flow switch

An air flow switch (which can be located at any blower) may be holding the control circuit open. The air flow switch senses a pressure differential across the blower. If there is no pressure differential, the heat control circuit is not closed. If the air flow switch opens, it will also reset the purge timer (if one exists). Operation and adjustment of the air flow switch are described on the manufacturer's literature. While the switch itself may be defective, an open switch may also be indicating other problems such as reverse blower rotation, slipping belts, obstructed ductwork, or a loose pressure connection or electrical connection at the switch itself.

8-1.2 A fuse burned out

In addition to the fuses in your fused disconnect switch, one or more fuses may be located inside the control panel as shown on the wiring diagram. Depending upon the particular furnace involved, it is possible for a fuse to open without affecting the pilot lights (or provide other visible sign) and still affect the heat circuit.

8.2 REDUCED OR INCORRECT FURNACE TEMPERATURE

8-2.1 Excessive Exhaust

Due to incorrect stack installation or unusual pressure conditions, the amount of heated air removed from the furnace may be excessive and result in a reduced operating temperature. In this case, the furnace heater will be running continuously, i.e., 100% output. This can be corrected by closing the exhaust damper until the maximum operating temperature is achieved. **CAUTION:** If the furnace is equipped for use with flammable solvents or is gas heated equipment, the exhaust capacity must not be reduced below the amount indicated on the Safety Design Form. See Section 5 - PROCESSING for information on balancing fresh air and exhaust settings.

8-2.2 Door Leakage

Damaged door gaskets (if applicable) combined with excessive exhaust could result in cold air being drawn in around the doorway. Replace or repair gaskets and adjust fresh air inlet. See Section 5 - PROCESSING, for adjustment of fresh air inlet.

8-2.3 Reduced Blower Speed

Loose or worn drive belts could prevent the recirculating blower (if so equipped) from attaining its design speed. This results in reduced air flow and inefficient heat transfer from the heat source to the work space.

8-2.4 Incorrect Blower Rotation

This results in reduced air flow and inefficient heat transfer from the heat source to the work area. Check blower rotation with respect to arrows located on furnace or motor mount. Run each blower briefly and watch shaft rotation to ensure correct rotation. See Section 4 - PRIOR TO PLACING FURNACE IN SERVICE, to correct blower rotation.

8-2.5 Defective or Improperly Calibrated Temperature Controller

See the temperature controller manufacturer's instructions for the proper operation and adjustment for the specific controller used.

8-2.6 Defective Thermocouples

Most temperature controllers and excess temperature limit interlocks are provided with thermocouples for sensing. These sensors are subject to drift over time. Compare known reading at sensor inside furnace to controller display. If it varies grossly, sensor may have to be replaced. If sensor is damaged or broken open, the controller display may give thermocouple error codes (see controller manual for proper error code meanings).

8-2.7 On Electrically Heated Furnaces - Improper Line Voltage

Voltage at the furnace should be measured to determine if an excessive line drop is causing reduced power input to the heating elements on an electrically heated furnace. This could be caused by too many devices connected to the same circuit or by undersized wiring between the furnace and the power source. Measure the voltage with the furnace heating elements on and all other equipment on the same circuit operating.

8-2.8 On Gas Heated Furnaces, Burner or Gas Pressure Adjustment

Contact your local gas company's service engineers. It is recommended to have them check all installations as they are aware of the many variables which can affect your operation. Correct gas pressure is essential. Measure gas pressure at the beginning of the furnace gas pipe train to ensure pressure agrees with the furnace nameplate requirement. If pressure drops as burner approaches high fire, there is insufficient gas supply.

8-3 EXCESS TEMPERATURE LIMIT INTERLOCK ACTUATION

Depending upon the specific device used, it may be tripped by either an excessively high furnace temperature or a sensing element failure. Before placing the equipment back into operation, it should be determined what caused the excess temperature limit interlock to actuate and the condition be corrected. See the excess temperature limit interlock manufacturer's literature for the proper operation and adjustment of the control used. **CAUTION:** If the furnace is equipped for use with flammable solvents or vapors, the excess temperature limit interlock is factory set at the maximum temperature allowed and should not be set to a higher temperature.

8-4 THE MOTOR STARTER OVERLOADS TRIPPED

All line voltage motors have current sensitive protective features in the motor starter. On magnetic motor starters, the "motor running" pilot light will not remain on if the overloads have tripped. The reset button is located on the motor starter inside the control panel. Measure motor amperage and compare to nameplate. If over amperage, determine cause and correct. If motor is only slightly over amperage, the overload can be increased to compensate. Motor amperage of blowers will drop as the furnace heats up and the air thins out reducing the load on the motor.

8-5 ON GAS HEATED FURNACES, PILOT WILL NOT LIGHT

A safe-start timer is built into the flame safety relay which will shut the system down if the pilot is not proven in approximately 10 seconds. If this timer trips, press the reset button on the flame safety relay near the gas burner. When the burner is inaccessible, a reset button will be on the control panel. See TROUBLE SHOOTING GAS HEATED EQUIPMENT procedures which is included in your manual if you have a gas heated furnace.

8-6 **INADEQUATE VENTILATION SYMPTOMS**

Vapor explosions often occur some time after ventilation becomes inadequate. Investigate the following symptoms and take corrective action immediately:

- a. A cold exhaust duct or stack while the furnace is operating usually indicates reversal of flow in the stack.
- b. Evidence of negative pressure in the furnace room, with respect to adjoining rooms and outdoors when the door to furnace room is opened, may indicate inadequate safety ventilation and sometimes reversal of airflow in the exhaust stack.
- c. A record of fires or puffs from work in a particular furnace may indicate inadequate safety ventilation, dangerously high vapor concentrations, the probability of an eventual serious furnace explosion.
- d. A record of work leaving the furnace with incomplete processing or unusual surface condition may be an indication of inadequate safety ventilation.
- e. Heavy deposits of condensed vapors at the exhaust stack outlet may indicate that interior fouling has dangerously reduced the safety ventilation.
- f. Deposits around furnace door cracks may indicate higher pressure inside the furnace than in the furnace room, and a lack of positive safety ventilation.

9 APPENDIX A - SAFETY EQUIPMENT DESCRIPTION & OPERATION

9-1 MANUAL RESET EXCESS TEMPERATURE LIMIT INTERLOCK (All)

This device will detect and be actuated when the temperature in the furnace work space exceeds a preset level. On actuation, the manual reset excess temperature limit interlock will open the control circuit to the main heat. In electrically heated furnaces the circuit is opened to the heating element contactors (or SCR power controller) and separate contactors. On gas heated equipment, the control circuit is opened to the control and safety valves.

To restore operation, the operator must manually reset the excess temperature limit interlock. This should be done only after determining the cause of overheating and correcting it. The manual reset excess temperature limit interlock is normally factory set at 50°F. above the maximum temperature of the furnace or, when known, 50°F. above your maximum process operating temperature. See the manufacturers operating instructions for adjusting the manual reset excess temperature limit interlock.

9-2 SEPARATE CONTACTOR(S) (Electric heat only)

A separate contactor(s) is connected in series with the main control contactor(s) (or SCR power controller) to open the circuit providing power to the heating elements. These separate contactors are powered through a series of safety interlocks including the manual reset excess temperature limit interlock. When any one of the safety interlocks open, the control circuit to the separate contactors is opened. The separate contactors provide additional protection which cannot be obtained with the main heating element contactors (or SCR power controller) alone. The redundant separate contactors provide a second cutoff device to the heating elements which does not cycle to maintain temperature and for this reason is less subject to wear.

9-3 DOOR HEATING ELEMENT INTERLOCK (Electric heat only)

Whenever door is not closed, a door heating element interlock is provided to open main contactors or SCR power controller and separate contactors to disconnect electric power from the heating elements. This interlock prevents the operator from coming in contact with electrically live heating element wires.

9-4 MAIN SAFETY SHUTOFF VALVES (Gas heat only)

Two (2) separate gas shutoff valves are connected in series with the gas control valve to close the pipeline providing gas to the main burner system. When all other safety equipment indicates proper operation and the gas burner pilot has been proven ignited, these devices are electrically energized and allow flow of gas to the main burner system. These gas shutoff valves are powered through a series of safety interlocks including the manual reset excess temperature limit interlock. When any one of the safety interlocks open, the control circuit to the gas shutoff valves are opened. The gas shutoff valves provide additional protection, which cannot be obtained with the gas control valve alone. The redundant gas shutoff valves provide gas flow shutoff devices, which do not cycle to maintain temperature and for this reason are less subject to wear.

9-5 PILOT SAFETY SHUTOFF VALVES (Gas Only)

On burners with a separate pilot burner, two (2) separate pilot gas shutoff valves are connected in series with the pilot burner to close the pipeline providing gas to the pilot. When all other safety equipment indicates proper operation and the gas burner pilot has been proven ignited, these devices are electrically energized and maintain flow of gas to the pilot burner. These pilot shutoff valves are powered through a series of safety interlocks including the manual reset excess temperature limit interlock. When any one of the safety interlocks open, the control circuit to the pilot shutoff valves are opened.

9-6 TEST DEVICE (Gas heat only)

On gas heated equipment, the test device is used as part of an inspection program to ensure that the main and pilot shutoff valves are sealing properly. (See Appendix D - Main Safety Shutoff Valve Leak Test Procedure and Pilot Safety Shutoff Valve Leak Test Procedure.)

9-7 VENT VALVE (Gas heat only, if requested by customer)

On gas heated equipment, the vent valve is used to vent the section of gas piping between the primary and secondary shut off valves. This is installed only at the customer's request. The customer must pipe outlet of vent valve to a safe location outside their building (in accordance with local codes) where any leaking gas will be safely dispersed into the atmosphere.

9-8 POWERED FORCED EXHAUSTER (If applicable)

As a safety device, the powered forced exhaust system is used to remove a definite volume of air when flammable solvents, vapors, gases or products of combustion are present in the furnace atmosphere. The exhaust rate must be properly sized to give safe operation and is determined from the quantity of material in the atmosphere and the operating temperature of the furnace. Reduced exhaust could result in an explosion or fire and bodily injury or property loss.

9-9 AIR FLOW SWITCH (If applicable)

This device senses pressure differential across an exhaust blower, recirculating blower or combustion burner blower to indicate that these blowers are moving air. When there is no pressure differential, the air flow switch opens and turns off the control circuit to the main heat. In electrically heated furnaces the circuit is opened to the heating element contactors (or SCR power controller) and separate contactors. On gas fired equipment, the control circuit is opened to the control and safety valves. Where failure of the air supply is critical to prevent a dangerous situation, this device is mandatory. The air flow switch picks up typical failures such as when a motor fails to turn the blower or when the blower drive belts are broken.

9-10 PURGE TIMER

Where it is necessary to ventilate the furnace prior to turning the heat on, a purge timer is installed. This purge period is typically required in gas heated equipment or when flammable solvents are present in the furnace's load. The purge timer ensures that the recirculating blower(s), powered forced exhauster(s) or combustion blower(s) are operating for a preset period of time prior to turning the heat on. The purge time is typically based on allowing sufficient time to pass four (4) furnace volumes of fresh air through the furnace. The time period is factory preset and is calculated based on the ventilation rate and total volume of the furnace within the insulated walls. The ventilation rate is based on the quantity of flammables entering the furnace and the operating temperature. In the case of gas heated equipment, the exhaust rate is also based on the combustion venting required for the burner system.

9-11 HIGH GAS PRESSURE SWITCH (Gas heat only)

This device is used on gas heated equipment to sense an abnormally high gas pressure which would affect the operation and safety of the equipment. If the gas pressure exceeds a preset level, the control circuit is opened to the safety valves. The installer must pipe, in accordance with local codes, the vent port on this switch to a safe location outside the building. Each such vent must be piped separately.

9-12 LOW GAS PRESSURE SWITCH (Gas heat only)

This device is used on gas heated equipment to detect an abnormally low gas pressure which would affect the operation and safety of the equipment. If the gas pressure drops below a preset level, the control circuit is opened to the control and safety valves. The installer must pipe, in accordance with local codes, the vent port on this switch to a safe location outside the building. Each such vent must be piped separately.

9-13 FLAME SAFEGUARD (Gas heat only)

On gas heated equipment, a solid state, electronic flame safeguard monitors each gas burner by use of a flame rod or ultra violet sensor. This device prevents burner operation unless the burner flame has been proven and maintained.

9-14 HEAT CHAMBER MANUAL RESET EXCESS TEMPERATURE LIMIT INTERLOCK (All)

This device is similar to the manual reset excess temperature limit interlock described previously except that the sensor is located in the heating element chamber or gas burner combustion chamber of the furnace.

This device will detect and be actuated when the temperature in the furnace heat chamber exceeds a preset level. On actuation, the heat chamber manual reset excess temperature limit interlock will open the control circuit to the main heat. In electrically heated furnaces, the circuit is opened to the heating element contactors (or SCR power controller) and separate contactors. On gas fired equipment, the control circuit is opened to the control and safety valves.

To restore operation, the operator must manually reset the heat chamber excess temperature limit interlock. This should be done only after determining the cause of overheating and correcting it. The heat chamber manual reset excess temperature limit interlock is set at the maximum temperature appropriate for the heat chamber. Typically the heat chamber will run substantially hotter than the furnace workspace. See the manufacturers operating instructions for adjusting the heat chamber manual reset excess temperature limit interlock.

10 APPENDIX B - REFERENCES

The following sources of additional information are provided for reference in these instructions. This is not presented as a complete list of all possible reference sources.

10.1 Factory Mutual Engineering Corporation
1151 Boston-Providence Turnpike
P.O. Box 9102
Norwood, MA 02062
Attn: Publications Order Processing

Specifications 6-9, Industrial Ovens and Dryers

10.2 National Fire Protection Association
One Batterymarch Park
Quincy, MA 02209-9101

Most current issue of:

NFPA 86 - Ovens and Furnaces

NFPA 70 - National Electric Code

NFPA 54 - National Fuel Gas Code

NFPA 10 - Standard for Portable Fire Extinguishers

NFPA 11 - Standard for Low-Expansion Foam

NFPA 12 - Standard on Carbon Dioxide Extinguishing Systems

NFPA 13 - Standard for the Installation of Sprinkler Systems

NFPA 14 - Standard for the Installation of Standpipe and Hose Systems

NFPA 15 - Standard for Water Spray Fixed Systems for Fire Protection

NFPA 17 - Standard for Dry Chemical Extinguishing Systems

NFPA 17A-Standard for Wet Chemical Extinguishing Systems

NFPA 25 - Standard for the Inspection, Testing and Maintenance of Water-Based
Fire Protection Systems

NFPA 30 - Flammable and Combustible Liquids Code

NFPA 31 - Standard for the Installation of Oil-Burning Equipment

NFPA 34 - Standard for Dipping and Coating Processes Using Flammable or
Combustible Liquids

NFPA 58 - Liquefied Petroleum Gas Code

NFPA 79 - Electrical Standard for Industrial Machinery

NFPA 91 - Standard for Exhaust Systems for Air Conveying of Vapors, Gases, Mists
and Noncombustible Particulate Solids

10.3 ASME Publications
American Society of Mechanical Engineers
345 East 47th Street
New York, NY 10017

The most current issue of:

ASME Boiler and Pressure Vessel Code

ASME B31.1 - Power Piping

ASME B31.3 - Process Piping

10.4 ANSI Publications:

American National Standards Institute
11 West 42nd Street, 13th Floor
New York, NY 10036

The most current issues of:

ANSI Z117-1 - Safety Requirements for Confined Spaces

11 **APPENDIX C - MINIMUM PERIODIC INSPECTION REPORT**

Model: _____ Serial No.: _____
Inspected By: _____ Date: _____

BEFORE APPLYING POWER CHECK THAT:

1. _____ No changes in process have been made including types of materials processed and temperature:

-Furnace originally designed for: _____

-Furnace being used for: _____

2. _____ If flammable solvents are involved in process, quantity entering furnace and operating temperature are within furnace design parameters -- see Operating Manual for Safety Design Form.

-Furnace designed for _____ gallons of solvent (per batch or per hour) at a maximum of _____ °F.

-Furnace being used for _____ gallons of solvent (per batch or per hour) at an operating temperature of _____ °F.

3. _____ All electrical connections are tight without stray strands.

4. _____ All contactors, relays, motor starters and other components with contacts have been inspected for wear or sticking.

5. _____ Furnace body inspected and painted surfaces touched up to prevent rusting.

6. _____ Furnace interior inspected for component assembly and positioning, cleaned, and all foreign matter removed from the following. Protect inspecting personnel from dust, see 7-2.

- _____ Floor
- _____ Heat chamber (including heating element surfaces)
- _____ Duct work
- _____ Air inlets
- _____ Exhaust outlets
- _____ Filters
- _____ Control enclosure and components
- _____ Door hinges or support mechanism

7. _____ Remove and clean all drip pans. Inspect and clean all work racks, trays, holders or spacers. Protect inspecting personnel from dust; see 7-2.

8. _____ Locate main temperature controller and excess temperature limit interlock thermocouples; inspect for damage. Make sure thermocouples are in free air and not touching anything.

9. _____ Top of furnace is clear; no material is stored on top of furnace.

10. _____ Doors are free to move and not obstructed.

11. ____ Exhaust duct work from furnace has been inspected and cleaned; all foreign matter removed.
12. ____ Fresh air duct work and/or filters have been inspected and cleaned; all foreign matter removed.
13. ____ Lubricate motors.
14. ____ Lubricate bearings on blower and exhauster shafts, belt conveyor shafts, door lift mechanism and other bearings.
15. ____ Lubricate explosion relief door latches (if so equipped) and check for freedom of movement.
16. ____ Adjust door for good seal around edges of door; gasket needs to only touch sealing surface, it does not need to be crushed. Inspect doors for damage and replace worn gasket if necessary.
17. ____ Inspect and tighten set screws between bearings and shafts on blower and exhauster, belt conveyor shafts, and other bearings on shafts.
18. ____ Inspect and replace, if necessary, V-belts on blowers, exhausters, combustion blowers, and other fans.
19. ____ Inspect blowers, exhauster, combustion blowers, and other fans for residue build-up on fan blades and housing. Clean as necessary. Tighten set screw holding fan to shaft.

APPLY POWER AND CHECK:

20. ____ Supply voltage agrees with furnace nameplate - measure between all three (3) phases and record; ____/____/____.
21. ____ Amperage (with everything running) agrees with furnace nameplate - measure all incoming lines and record; ____/____/____.
22. ____ Check that all blowers, exhausters, combustion blowers and other fans are rotating in the correct direction.
23. ____ Check exhaust rate if it is critical for safe operation such as required for removing flammable solvents or combustion venting. This test should be with all volume controls (dampers) at minimum setting. Reference Safety Design Form for required exhaust rate.

ELECTRIC FURNACES

24. ____ Check that temperature controller does not cycle separate (back-up) contactors.
25. ____ Shut down furnace and make sure main contactors (or SCR power controller) and separate contactors all open.
26. ____ Inspect heating elements for contamination, distortion and adequate support.
27. ____ Check electrical connection at heating element terminals for tightness.

FUEL GAS FURNACES

28. ____ Check pilot safety shutoff valves for leakage. (See Appendix D for details.)
29. ____ Check main safety shutoff valves for leakage. (See Appendix D for details.)

30. ____ Check that vent valve (if installed) is closed when main burner is firing.
31. ____ Turning up low gas pressure switch setting shuts all valves and resets purge timer. Return to original setting. Low gas pressure switch set at _____.
32. ____ Turning down high gas pressure switch shuts all valves and resets purge timer. Return to original. High setting gas pressure switch set at _____.
33. ____ Lubricate gas cocks.
34. ____ Locate remote emergency shut off valve, lubricate and operate to confirm free movement.
35. ____ Number of safety shut off valve cycles should be estimated and safety shut off valves replaced after 90% of lifetime cycles have been reached. Cycle estimate can be made by multiplying number of years of service by 260 days per year (5 day work week) by number of times furnace is turned on and off daily.
36. ____ Pilot and main burner light easily.
37. ____ Main flame blue with yellow tips.
38. ____ Flame rod clean and positioned correctly.
39. ____ Gas pressure set at pressure shown on nameplate. Setting is _____
40. ____ Control valve linkage tight and operates smoothly over full range of travel.
41. ____ Test flame safety relay by closing main burner gas cock and pilot burner gas cock causing flame relay to shut down burner by closing both safety valves and both pilot valves.

SAFETY SWITCHES

42. ____ Check door heating element interlock to make sure, that as door opens, main contactors (or SCR controller) and separate (back up) contactors open, disconnecting electric power from heating elements.
43. ____ Disconnect both air tubes at each air flow switch to make sure furnace heat is shut down on air flow switch deactivation.
44. ____ Check that purge timer is set for purge time shown on Safety Design Form and Caution nameplate installed adjacent to purge timer. Confirm purge time by checking against clock and record. _____

TEMPERATURE CONTROLS

45. ____ Heat furnace to operating temperature and check temperature controller calibration.
46. ____ Compare temperature controller indication and excess temperature limit interlock I indication to confirm they are similar.
47. ____ Disconnect one side of thermocouple connection to confirm upscale break protection is operating on main temperature controller and excess temperature limit interlock.
48. ____ To check excess temperature limit interlock function, heat furnace above excess temperature limit interlock setpoint. Make sure excess temperature limit interlock shuts down heat by opening main contactor (or SCR power controller) and separate contactors on electric furnaces and closes all gas valves on gas furnace.
49. ____ Excess temperature limit interlock is set no higher than 50°F above maximum operating temperature of furnace.

LOCATION

- 50. ____ No changes in the furnace area have created a hazardous condition such as external heat, vibration, mechanical hazard or corrosive environment.
- 51. ____ No process change has resulted in flammable liquids or explosive vapors or dust cloud being stored or produced in vicinity of furnace.
- 51. ____ Portable fire extinguishers in the area have been inspected.
- 52. ____ Fire suppression systems, such as a sprinkler system, have been inspected.
- 54. ____ Sprinkler heads in furnace and duct work have been inspected and cleaned.

TRAINING

- 55. ____ Review job function, furnace operation and emergency shutdown with operators and supervisors.

12 APPENDIX D - SAFETY SHUT OFF VALVE LEAK TEST PROCEDURE

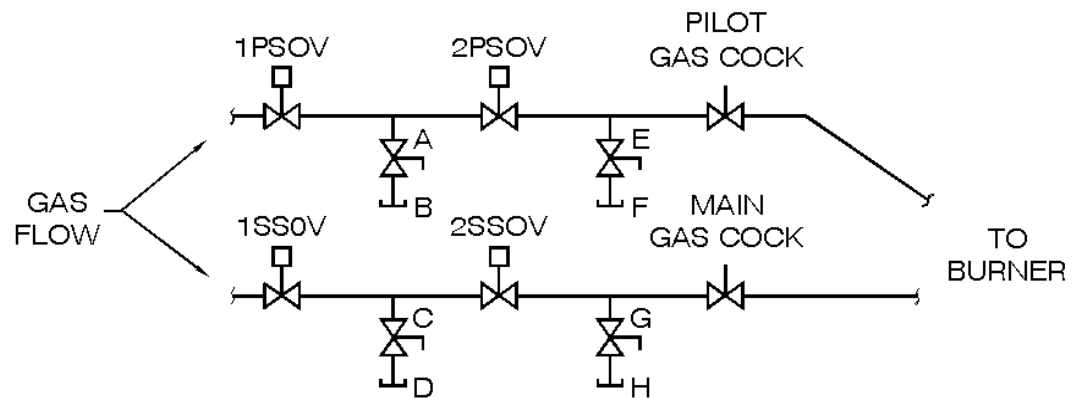

FIRST PILOT SHUT OFF VALVE (1PSOV)

1. Make sure all gas cocks ahead of equipment are open to allow gas flow to equipment and turn off electrical power to the control panel to assure that there is no power to the pilot shut off solenoid valves so that they are closed (1PSOV & 2PSOV).
2. Make sure the manual test petcock (A) is closed.
3. Remove the leak test tap plug (B) and connect 1/4" tube to the petcock.
4. Close the pilot gas cock located between the pilot shut off solenoid valves and the burner.
5. Immerse the 1/4" tube vertically 1/2 inch into a jar of water.
6. Slowly open the test petcock (A).
7. Gas will bubble through the water and stop. If bubbles continue, the valve is leaking and must be replaced. Do not continue to operate burner until valve is replaced.
8. Close the test petcock (A), remove the 1/4" tube and replace the leak test tap plug (B).

FIRST SAFETY SHUT OFF VALVE (1SSOV)

9. Make sure all gas cocks ahead of equipment are open to allow gas flow to equipment and turn off electrical power to the control panel to assure that there is no power to the safety shut off solenoid valves so that they are closed (1SSOV & 2SSOV).
10. Make sure the manual test petcock (C) is closed.
11. Remove the leak test tap plug (D) and connect 1/4" tube to the petcock.
12. Close the main gas cock located between the safety shut off solenoid valves and the burner.
13. Immerse the 1/4" tube vertically 1/2 inch into a jar of water.
14. Slowly open the test petcock (C).
15. Gas will bubble through the water and stop. If bubbles continue, the valve is leaking and must be replaced. Do not continue to operate burner until valve is replaced.
16. Close the test petcock (C), remove the 1/4" tube and replace the leak test tap plug (D).

12 APPENDIX D - SAFETY SHUT OFF VALVE LEAK TEST PROCEDURE (cont'd)

SECOND PILOT SHUT OFF VALVE (2PSOV)

17. Make sure all gas cocks ahead of equipment are open to allow gas flow to equipment and power is provided to the control panel. Turn on the Exhauster but do not turn HEAT switch to start to assure that there is no power to the pilot shut off solenoid valves so that they are closed (1PSOV & 2PSOV).
18. Make sure the manual test petcock (E) is closed.
19. Remove the leak test tap plug (F) and connect 1/4" tube to the petcock.
20. Close the downstream pilot gas cock located between the pilot shut off solenoid valves and burner.
21. Immerse the 1/4" tube vertically ½ inch into a jar of water.
22. Depress and hold the VALVE TEST button located at the burner junction box to open the first pilot shut off solenoid valve (1PSOV) and allow gas pressure to the second pilot shut off solenoid valve (2PSOV).
23. While holding VALVE TEST button in, slowly open the test petcock (E).
24. Gas will bubble through the water and stop. If bubbles continue, the valve is leaking and must be replaced. Do not continue to operate burner until valve is replaced.
25. Release VALVE TEST button. Close the test petcock (E), remove the 1/4" tube and replace the leak test tap plug (F).
26. Open the pilot gas cock located between the pilot shut off solenoid valves and the burner.

SECOND SAFETY SHUT OFF VALVE (2SSOV)

27. Turn on the Blower (Gas cocks open and exhauster still running from step 17) and turn the HEAT switch to "START". System will purge and ignite pilot causing main safety shut off valve (1SSOV) and secondary safety shut off valve (2SSOV) to open.
28. Make sure the manual test petcock (G) is closed.
29. Remove the leak test tap plug (H) and connect 1/4" tube to the petcock.
30. Close the main gas cock located between the safety shut off solenoid valves and burner.
31. Immerse the 1/4" tube vertically 1/2 inch into a jar of water.
32. Depress and hold VALVE TEST button located at burner junction box to cause secondary safety shut off solenoid valve (2SSOV) to close. (NOTE: If customer requested vent valve is installed, vent valve will also close at this point. Check to make sure vent valve closes and that no gas is passing from vent valve outlet. To do this, the location of the outlet vent pipe must be found where it exits the building.)
33. While holding VALVE TEST button in, slowly open the test petcock (G).
34. Gas will bubble through the water and stop. If bubbles continue, the valve is leaking and must be replaced. Turn HEAT switch to "OFF". Do not continue to operate burner until valve is replaced.

12 APPENDIX D - SAFETY SHUT OFF VALVE LEAK TEST PROCEDURE (cont'd)

SECOND SAFETY SHUT OFF VALVE (2SSOV) (cont'd)

35. Close the test petcock (G). Release test button. Remove the 1/4" tube and replace the leak test tap plug (H).

36. Open the main gas cock located between the safety shut off solenoid valves and burner.

Any equipment sold by GRIEVE is warranted for one (1) year after the Purchaser receives the equipment to be free from defects of material and workmanship. THERE ARE NO WARRANTIES WHICH EXTEND BEYOND THE DESCRIPTION ON THE FACE HEREOF; WITHOUT LIMITING THE GENERALITY OF THE FOREGOING, GRIEVE EXPRESSLY DISCLAIMS ALL IMPLIED WARRANTIES, INCLUDING THE WARRANTIES OF MERCHANTABILITY AND FITNESS FOR A PARTICULAR PURPOSE. THE PURCHASER'S EXCLUSIVE REMEDY FOR ANY BREACH OF THIS WARRANTY SHALL BE FOR THE REPAIR OR REPLACEMENT (AT GRIEVE'S OPTION) OF THE DEFECTIVE EQUIPMENT OR PART.

Parts under warranty are shipped via ground transportation. Express or expedited shipping costs are the sole responsibility of the customer. In order to obtain repair or replacement under this warranty, the user must deliver the defective product or part to GRIEVE's factory on a prepaid basis promptly after discovery of the defect. GRIEVE's warranty ceases to be effective if the equipment is altered or modified, repaired other than by persons authorized by GRIEVE, misused, used by any person in an unsafe or unreasonable manner or used other than in accordance with GRIEVE's written instructions. Although GRIEVE makes no additional or extended warranty with respect to thermostats, recorders, control equipment or other accessories, to the extent such items may also be warranted by their respective manufacturers, those warranties are passed on to you by GRIEVE as agent of the respective manufacturer and not as a separate warrantor.

In no event shall GRIEVE be liable for any direct, indirect, special, incidental or consequential damages hereunder, whether such damages are sought based on breach of warranty, breach of contract, negligence, strict liability in tort, or any other theory of legal liability.



Ovens and Furnaces For Industry Since 1949

THE GRIEVE CORPORATION

500 Hart Road, Round Lake, Illinois 60073-2898 USA

(847) 546-8225 Fax: (847) 546-9210

www.grievcorp.com email: sales@grievcorp.com