



**Acme Electric
Corporation**

Power Distribution Products Division

SECONDARY VOLTAGE 12/24

BUCK & BOOST TRANSFORMER INSTALLATION INSTRUCTIONS

Steps for Selecting the Proper Buck-Boost Transformer

First, you should have this information before selecting a buck-boost transformer.

Line Voltage—The voltage that you want to buck (decrease) or boost (increase). This can be found by measuring the supply line voltage with a voltmeter.

Load Voltage—The voltage at which your equipment is designed to operate. This is listed on the nameplate of the load equipment.

Load KVA or Load Amps — You do not need to know both—one or the other is sufficient for selection purposes. This information usually can be found on the nameplate of the equipment that you want to operate.

Frequency—The supply line frequency must be the same as the frequency of the equipment to be operated—either 50 or 60 cycles.

Phase—The supply line should be the same as the equipment to be operated—either single or three phase.

4 Step Selection

1 A series of LINE VOLTAGE and LOAD VOLTAGE combinations are listed across the top of each selection chart. Select a LINE VOLTAGE and LOAD VOLTAGE combination from ANY of the charts that comes closest to matching the LINE VOLTAGE and LOAD VOLTAGE of your application.

2 Read down the column you have selected until you reach either the LOAD KVA or LOAD AMPS of the equipment you want to operate. You probably will not find the exact value of LOAD KVA or LOAD AMPS so go to the next higher rating.

3 From this point, read across the column to the far left-hand side and you have found the catalog number of the exact buck-boost transformer you need.

4 CONNECT the transformer according to the connection diagram specified at the bottom of the column where you selected your LINE VOLTAGE and LOAD VOLTAGE combination.

Connection Diagrams – Single Phase

Autotransformer Overcurrent Protection

- 1 The symbol “O” used in these single phase connection diagrams illustrates where to field install an overcurrent protective device (typically a fuse or circuit breaker) when one input conductor is grounded and the other input conductor is ungrounded.
- 2 When both input conductors are ungrounded, an overcurrent protection device is required to be installed in series with each input conductor.
- 3 When the input and output are reversed, always install the overcurrent protection device in series with the input conductor(s), as noted in items No. 1 and No. 2 shown above.
- 4 For additional information, refer to the National Electrical Code, Article 450-4.

Only 1 Transformer is Required in Figure Shown Below

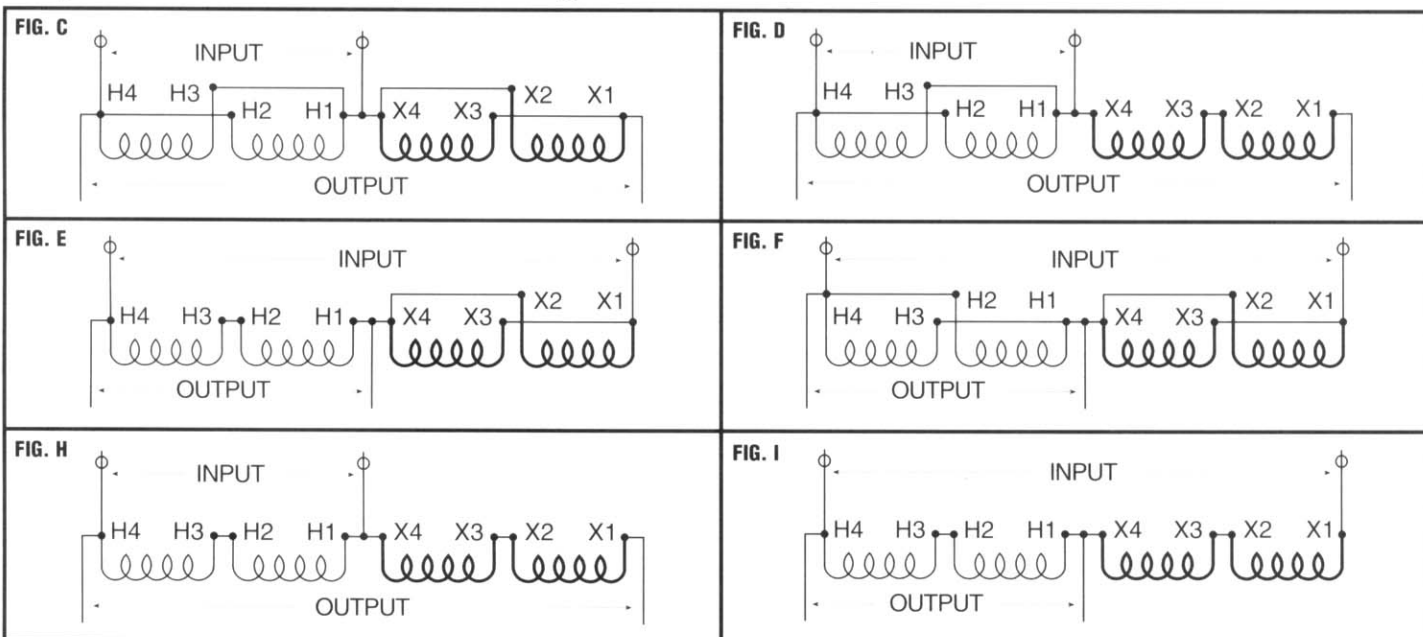

CAUTION: DO NOT USE CONNECTIONS OTHER THAN THOSE SHOWN OR PROVIDED BY FACTORY

INPUT VOLTAGE 120 X 240: OUTPUT VOLTAGE 12 X 24: 60 Hz

* All Sizes Of 3/4 KVA And Less Are Suitable For 50/60 Hz

Units Rated 120 x 240 V Input: 12 x 24 V Output		
INPUT	OUTPUT	CONNECTION DIAGRAM
120	12	K
120	24	L
240	12	M
240	24	N

CATALOG NUMBER	INSULATING TRANSFORMER RATING	MAX. CURRENT OUTPUT	
		12 V	24 V
T-1-81047	* 50 VA	4.16	2.08
T-1-81048	* 100 VA	8.32	4.16
T-1-81049	* 150 VA	12.52	6.25
T-1-81050	0.25 KVA	20.80	10.40
T-1-81051	0.50 KVA	41.60	20.80
T-1-81052	0.75 KVA	62.50	31.25
T-1-11683	1.00 KVA	83.20	41.60
T-1-11684	1.50 KVA	125.00	62.50
T-1-11685	2.00 KVA	166.00	83.20
T-1-11686	3.00 KVA	250.00	125.00
T-1-11687	5.00 KVA	416.00	208.00
T-2-11688	7.50 KVA	625.00	312.50
T-2-11689	10.00 KVA	832.00	416.00

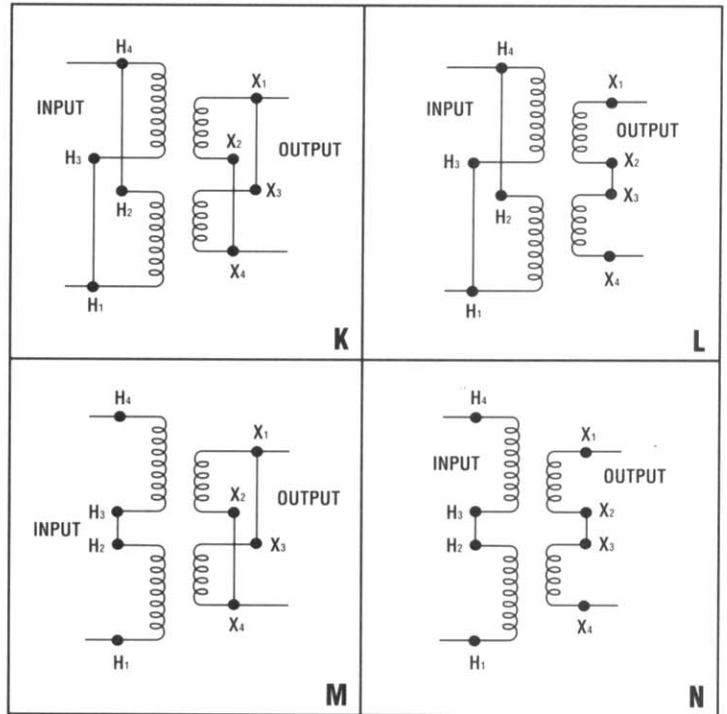

Three Phase Connections

CAUTION: DO NOT USE CONNECTIONS OTHER THAN THOSE SHOWN OR PROVIDED BY FACTORY.

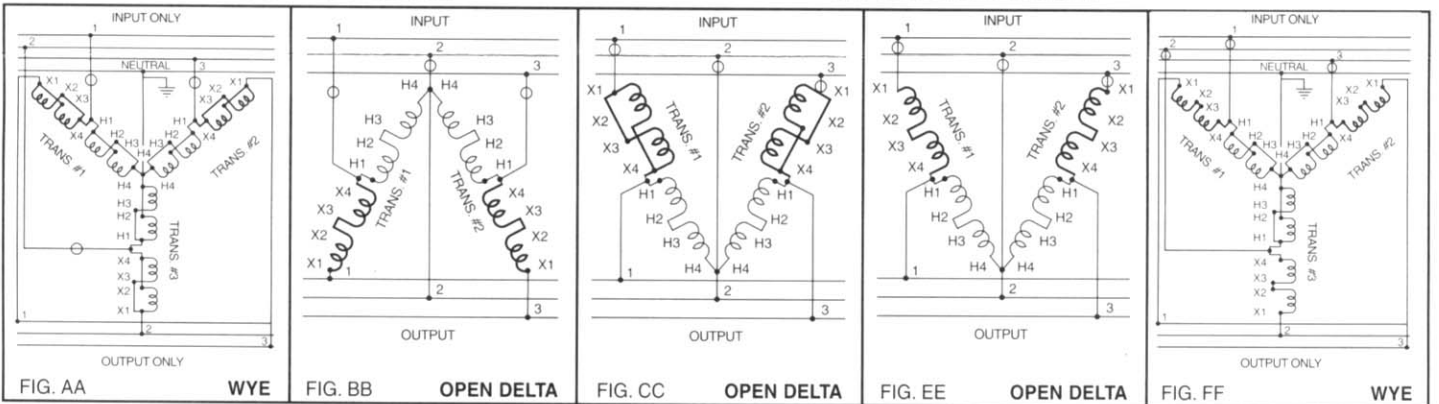

Typical Buck-Boost Autotransformer Installation

The number of Buck-Boost Transformers is shown on the connection used. It may vary from the number shown in this illustration.

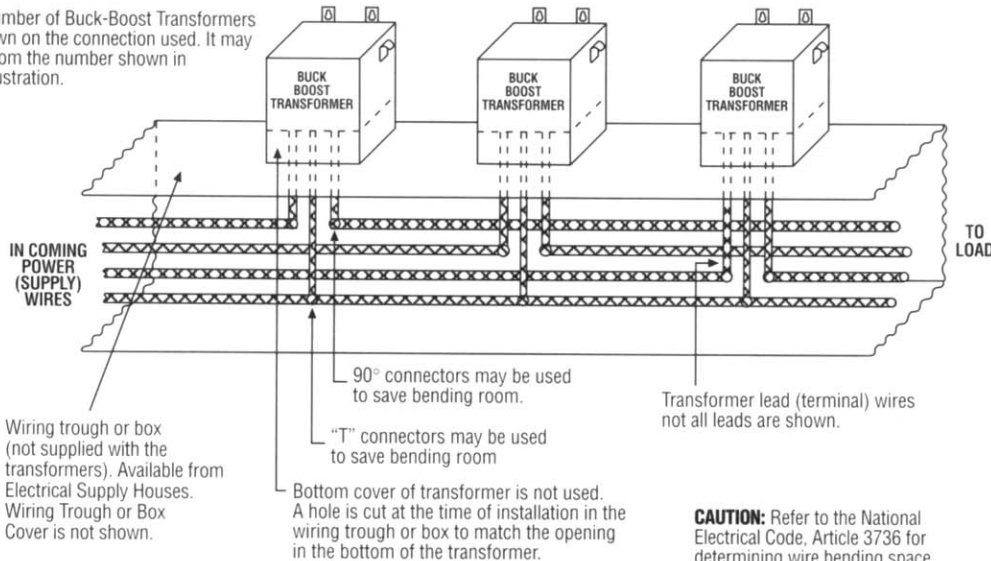

Autotransformer Overcurrent Protection

The symbol "O" used in these three phase connection diagrams illustrates where to field install an overcurrent protective device (typically a fuse or circuit breaker).

When the input and output are reversed, always install the overcurrent protective device in series with the input conductors.

For additional information, refer to the National Electrical Code, Article 450-4.

CAUTION: Refer to the National Electrical Code, Article 3736 for determining wire bending space.

USE INFORMATION BELOW FOR SINGLE PHASE AUTOTRANSFORMER CONNECTIONS



GROUP I

SINGLE PHASE		BOOSTING							
Line Voltage (Available)		95	100	105	110	189	208	215	220
Load Voltage (Output)		114	120	115	120	208	230	237	242
CAT. NO. ▲ (SEE FOOTNOTE)									
T-1-81047	Load KVA Amps	0.24 2.08	0.25 2.08	0.48 4.17	0.50 4.17	0.43 2.08	0.48 2.08	0.49 2.08	0.50 2.08
	Max. Size of Fuse or Breaker	6	6	10	10	6	6	6	6
T-1-81048	Load KVA Amps	0.47 4.17	0.50 4.17	0.96 8.33	1.01 8.33	0.87 4.17	0.96 4.17	0.99 4.17	1.01 4.17
	Max. Size of Fuse or Breaker	10	10	15	15	10	10	10	10
T-1-81049	Load KVA Amps	0.71 6.25	0.75 6.25	1.43 12.50	1.51 12.50	1.30 6.25	1.43 6.25	1.48 6.25	1.51 6.25
	Max. Size of Fuse or Breaker	15	15	20	20	15	15	15	15
T-1-81050	Load KVA Amps	1.19 10.42	1.25 10.40	2.40 20.80	2.50 20.80	2.16 10.40	2.39 10.40	2.46 10.40	2.52 10.40
	Max. Size of Fuse or Breaker	25	25	40	30	15	15	15	15
T-1-81051	Load KVA Amps	2.37 20.83	2.50 20.83	4.80 41.67	5.00 41.67	4.33 20.83	4.79 20.83	4.93 20.83	5.04 20.83
	Max. Size of Fuse or Breaker	35	35	60	60	30	30	30	30
T-1-81052	Load KVA Amps	3.56 31.25	3.75 31.25	7.17 62.50	7.56 62.50	6.50 31.25	7.19 31.25	7.41 31.25	7.56 31.25
	Max. Size of Fuse or Breaker	50	50	90	90	45	45	45	45
T-1-11683	Load KVA Amps	4.75 41.67	5.00 41.67	9.58 83.31	10.00 83.31	8.66 41.67	9.58 41.67	9.87 41.67	10.00 41.67
	Max. Size of Fuse or Breaker	70	70	125	125	60	60	60	60
T-1-11684	Load KVA Amps	7.12 62.50	7.50 62.50	14.40 125.00	15.10 125.00	13.00 62.50	14.30 62.50	14.80 62.50	15.10 62.50
	Max. Size of Fuse or Breaker	100	100	175	175	90	90	90	90
T-1-11685	Load KVA Amps	9.50 83.30	10.00 83.30	19.20 166.60	20.20 166.60	17.30 83.30	19.16 83.30	19.70 83.30	20.10 83.30
	Max. Size of Fuse or Breaker	125	125	250	250	125	125	125	125
T-1-11686	Load KVA Amps	14.20 125.00	15.00 125.00	28.80 250.00	30.00 250.00	26.00 125.00	28.70 125.00	29.60 125.00	30.30 125.00
	Max. Size of Fuse or Breaker	200	200	350	350	175	175	175	175
T-1-11687	Load KVA Amps	23.70 208.00	25.00 208.00	47.90 416.60	50.00 416.60	43.30 208.00	47.80 208.00	49.30 208.00	50.30 208.00
	Max. Size of Fuse or Breaker	350	350	600	600	300	300	300	300
T-2-11688 *	Load KVA Amps	35.60 312.50	37.50 312.50	71.90 625.00	75.60 625.00	65.00 312.50	71.80 312.50	74.00 312.50	75.60 312.50
	Max. Size of Fuse or Breaker	500	500	1000	1000	450	450	450	450
T-2-11689 *	Load KVA Amps	47.50 416.60	50.00 416.60	95.80 833.30	100.00 833.30	86.60 416.60	95.80 416.60	98.70 416.60	101.00 416.60
	Max. Size of Fuse or Breaker	700	700	1200	1200	600	600	600	600
Connection Diagram		D	D	C	C	H	H	H	H

SINGLE PHASE

BUCKING					
125	132	230	245	250	252
113	120	208	222	227	240
0.52 4.60	0.54 4.60	0.47 2.28	0.50 2.28	0.52 2.28	1.02 4.37
10	10	6	6	6	10
1.04 9.20	1.08 9.20	0.95 4.56	1.00 4.56	1.04 4.58	2.04 8.75
15	15	10	10	10	15
1.56 13.80	1.62 13.80	1.42 6.86	1.50 6.86	1.56 6.86	3.00 13.10
20	20	15	15	15	15
2.60 22.80	2.75 22.80	2.37 11.40	2.50 11.40	2.60 11.40	5.10 21.80
30	30	15	15	15	30
5.20 46.80	5.40 46.80	4.74 22.80	5.00 22.80	5.20 22.80	10.20 43.70
60	60	30	30	30	60
7.80 68.50	8.15 69.50	7.10 34.40	7.50 34.40	7.80 34.40	15.30 65.50
80	80	40	40	40	80
10.40 91.50	10.80 91.50	9.50 45.80	10.00 45.80	10.00 45.80	20.40 87.50
110	110	60	60	50	110
15.00 138.00	16.20 138.00	14.24 68.60	15.00 68.60	15.60 68.60	30.60 132.00
150	175	80	80	80	175
20.80 183.00	21.60 183.00	19.00 91.60	20.00 91.60	20.30 91.20	40.80 175.00
225	225	110	110	110	225
31.20 275.00	32.50 275.00	28.50 136.80	30.00 136.80	31.20 136.80	61.00 263.00
350	350	175	175	175	350
52.00 457.00	54.00 457.00	47.40 228.00	50.00 228.00	52.00 228.00	102.00 437.00
600	600	300	300	300	600
78.00 688.00	81.00 688.00	71.00 344.00	76.00 344.00	78.00 344.00	153.00 655.00
800	800	400	400	400	800
104.00 915.00	108.00 915.00	95.00 458.00	100.00 458.00	104.00 458.00	204.00 875.00
1200	1200	600	600	600	1200
F	F	I	I	I	E

NOTE: Inputs and Outputs may be reversed; KVA capacity remains constant. All applications **above** bold face line are suitable for 50/60 Hz. All applications **below** bold face line are suitable for 60 Hz only.

IMPORTANT: Refer to the N.E.C. (National Electrical Code) Article 450-4 for Overcurrent Protection of an Autotransformer.

▲ The first digit of the catalog number appearing on the transformer name plate may be different than what is shown on this instruction sheet;
EXAMPLE: T-1 or T-2 or T-3 and ETC.

Larger KVA buck-boost transformers utilize multiple conductors on the secondary (X) terminals as shown below.

	NUMBER OF LEADS PER TERMINATION							
	H1	H2	H3	H4	X1	X2	X3	X4
T-2-11688	1	1	1	1	2	2	2	2
T-2-11689	1	1	1	1	2	2	2	2

All leads with same designation (ex. X1, X1) MUST be joined together for proper operation.

USE INFORMATION BELOW FOR THREE PHASE AUTOTRANSFORMER CONNECTIONS



GROUP I

THREE PHASE		BOOSTING						
Line Voltage (Available)		189Y 109	196Y 113	201Y 116	208Y 120	189	208	220
Load Voltage (Output)		208	234	240	230	208	230	242
CAT. NO. ▲ (SEE FOOTNOTE) SHOWN ON PG. 2								
T-1-81047	Load KVA Amps	1.50 4.17	0.84 2.08	0.87 2.08	1.66 4.17	0.75 2.08	0.83 2.08	0.87 2.08
	Max. Size of Fuse or Breaker	10	6	6	10	6	6	6
T-1-81048	Load KVA Amps	3.00 8.33	1.69 4.17	1.73 4.17	3.32 8.33	1.50 4.17	1.66 4.17	1.75 4.17
	Max. Size of Fuse or Breaker	15	10	10	15	10	10	10
T-1-81049	Load KVA Amps	4.50 12.50	2.53 6.25	2.60 6.25	4.98 12.50	2.25 6.25	2.49 6.25	2.62 6.25
	Max. Size of Fuse or Breaker	20	15	15	20	15	15	15
T-1-81050	Load KVA Amps	7.51 20.83	4.22 10.42	4.33 10.42	8.30 20.83	3.75 10.42	4.15 10.42	4.37 10.42
	Max. Size of Fuse or Breaker	30	20	20	30	15	15	15
T-1-81051	Load KVA Amps	15.01 41.67	8.44 20.83	8.66 20.83	16.60 41.67	7.51 20.83	8.30 20.83	8.73 20.83
	Max. Size of Fuse or Breaker	60	35	35	60	30	30	30
T-1-81052	Load KVA Amps	22.52 62.50	12.67 31.25	12.99 31.25	24.90 62.50	11.26 31.25	12.45 31.25	13.10 31.25
	Max. Size of Fuse or Breaker	90	50	50	90	45	45	45
T-1-11683	Load KVA Amps	30.02 83.33	16.89 41.67	17.32 41.67	33.20 83.33	15.01 41.67	16.60 41.67	17.46 41.67
	Max. Size of Fuse or Breaker	125	70	70	125	60	60	60
T-1-11684	Load KVA Amps	45.03 125.00	25.33 62.50	25.98 62.50	49.80 125.00	22.52 62.50	24.90 62.50	26.20 62.50
	Max. Size of Fuse or Breaker	175	100	100	175	90	90	90
T-1-11685	Load KVA Amps	60.04 166.67	33.77 83.33	34.64 83.33	66.40 167.67	30.02 83.33	33.20 83.33	34.93 83.33
	Max. Size of Fuse or Breaker	250	125	125	250	125	125	125
T-1-11686	Load KVA Amps	90.07 250.00	50.66 125.00	51.96 125.00	99.59 250.00	45.03 125.00	49.80 125.00	52.39 125.00
	Max. Size of Fuse or Breaker	350	200	200	350	175	175	175
T-1-11687	Load KVA Amps	150.11 416.67	84.44 208.33	86.60 208.33	165.99 416.67	75.06 208.33	82.99 208.33	87.32 208.33
	Max. Size of Fuse or Breaker	600	350	350	600	300	300	300
T-2-11688 *	Load KVA Amps	225.17 625.00	126.66 312.50	129.90 312.50	248.98 625.00	112.58 312.50	124.49 312.50	130.99 312.50
	Max. Size of Fuse or Breaker	1000	500	500	1000	450	450	450
T-2-11689 *	Load KVA Amps	300.22 833.33	168.87 416.67	173.21 416.67	331.98 833.33	150.11 416.67	165.99 416.67	174.65 416.67
	Max. Size of Fuse or Breaker	1200	700	700	1200	600	600	600
Quantity Required		3	3	3	3	2	2	2
Connection Diagrams		A-A	F-F	F-F	A-A	B-B	B-B	B-B

THREE PHASE

BUCKING				
219	230	250	255	264
208	208	227	232	240
1.58 4.39	0.83 2.30	0.90 2.29	0.92 2.29	0.95 2.29
10	6	6	6	6
3.16 8.77	1.66 4.61	1.80 4.59	1.84 4.58	1.91 4.58
15	10	10	10	10
4.74 13.16	2.49 6.91	2.71 6.88	2.76 6.87	2.86 6.88
20	15	15	15	15
7.90 21.94	4.15 11.52	4.51 11.47	4.60 11.45	4.76 11.46
30	15	15	15	15
15.80 43.87	8.30 23.04	9.02 22.94	9.20 22.90	9.53 22.92
60	30	30	30	30
23.71 65.81	12.45 34.56	13.53 34.42	13.80 34.35	14.29 34.38
80	40	40	40	40
31.61 87.74	16.60 46.07	18.04 45.89	18.40 45.80	19.05 45.83
110	60	60	60	60
47.41 131.61	24.90 69.11	27.06 68.83	27.60 68.70	28.58 68.75
175	80	80	80	80
63.22 175.48	33.20 92.15	36.08 91.78	36.81 91.59	38.11 91.67
225	110	110	110	110
94.83 263.22	49.80 138.22	54.13 137.67	55.21 137.39	57.16 137.50
350	175	175	175	175
158.05 438.70	82.99 230.37	90.21 229.44	92.02 228.99	95.26 229.17
600	300	300	300	300
237.07 658.05	124.49 345.55	135.32 344.16	138.02 343.48	142.89 343.75
800	400	400	400	400
316.10 877.40	165.99 460.74	180.42 458.88	184.03 457.97	190.53 458.33
1200	600	600	600	600
2	2	2	2	2
C-C	E-E	E-E	E-E	E-E

NOTE: (1) Inputs and Outputs may be reversed; KVA capacity remains constant. All applications **above** bold face line are suitable for 50/60 Hz. All applications **below** bold face line are suitable for 60 Hz only.
(2) Connection Diagrams A-A and F-F cannot be reverse connected.

IMPORTANT: Refer to the N.E.C. (National Electrical Code) Article 450-4 for Overcurrent Protection of an Autotransformer.

Larger KVA buck-boost transformers utilize multiple conductors on the secondary (X) terminals as shown below.



Acme Electric Corporation

Power Distribution Products Division

4815 W. 5th Street
Lumberton, NC 28358-0499
FAX (910) 739-0024
www.acmepowerdist.com
SALES:
(910) 738-1121 Inside NC
(800) 334-5214 Outside NC

	NUMBER OF LEADS PER TERMINATION							
	H1	H2	H3	H4	X1	X2	X3	X4
T-2-11688	1	1	1	1	2	2	2	2
T-2-11689	1	1	1	1	2	2	2	2

All leads with same designation (ex. X1, X1) MUST be joined together for proper operation.